

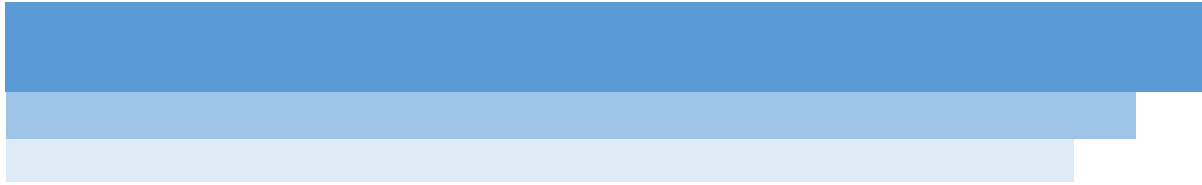

INSTALLATION MANUAL



February 2017

CONTENTS

February 2017

This manual is to be read in conjunction with the Product Specifications & Assembly manual

SECTION NO.	DESCRIPTION	PAGE NO.
SECTION 1 – TOOLS & ADDITIONAL ITEMS REQUIRED		1.1
SECTION 2 – INSTALLATION		2.4
	PART A – PREPARING INSTALLATION SPACE	2.4
	PART B – SPRING PRE-TENSIONING	2.7
	PART C – BOX INSTALLATION	2.12
	PART D – FASCIA INSTALLATION	2.14
	PART E – OPEN BRACKET INSTALLATION	2.16
	PART F – SHADE INSTALLATION	2.18
	PART G – SIDE GUIDE INSTALLATION	2.22
	PART H –ULTRA-LOCK LATCH INSTALLATION	2.29
	PART I – ULTRA-LOCK TROUBLE SHOOTING	2.33
	PART J – WEIGHT BAR SB07 LATCH INSTALLATION	2.34
	PART K – INSERT BOX / FASCIA	2.36
SECTION 3 – INSTALLATION SCENARIOS		3.1
	PART A – MULTIPLE SHADES INSTALLED SIDE BY SIDE ON A WALL MOUNT INSTALLATION	3.1
SECTION 4 – TROUBLESHOOTING		4.1

DISCLAIMER

INTRODUCTION

This Installation manual has been produced by TEXTON to supply the necessary information for safe and correct installation of this system.

INSTALLERS RESPONSIBILITY

Before installing, please read & ensure you understand the safety information and installation instructions as defined in this installation manual.

- If you do not fully understand these instructions, contact TEXTON for clarification before installing.
- The Installer is responsible to ensure that all installation personnel have been adequately trained on the safe & correct installation and operation.
- The Installer is responsible to ensure that supporting structures are sound and can adequately support the load.
- The Installer is responsible to ensure that the devices used to anchor the product to the supporting structure are suitable for the application.

SAFETY INFORMATION

- Ensure that electrical works are done only by a LICENSED ELECTRICIAN.
- DO NOT modify any of the components of this system.

PERSONNEL REQUIREMENTS

Only suitably trained/qualified personnel should undertake installation.

DISCLAIMER

TEXTON has used reasonable care in preparing the information included in this document, but makes no representations or warranties as to the completeness or accuracy of the information. Information is supplied upon the condition that the persons receiving the information will make their own determination as to its suitability for their purposes prior to use. TEXTON assumes no liability whatsoever for any damages incurred by you resulting from errors in or omissions from the information included herein. TEXTON reserves the right to make changes without further notice to any products to improve reliability, function or design.

COPYRIGHT

COPYRIGHT © TEXTON INC 2017

All rights reserved. No part of this document may be reproduced or utilized in any means, by any means, electronic or mechanical including photocopying, recordings, or by any information storage or retrieval system, without the express permission from TEXTON.

SECTION 1 – TOOLS & ADDITIONAL ITEMS REQUIRED

TOOLS REQUIRED

- Saw
- Drill
- Drill Bits – 2.5mm, 2.6mm, 3mm, 3.2mm & 4mm
- Screw Driver – Philips Head
- Scissors
- Measuring Tape

ADDITIONAL ITEMS REQUIRED (NOT SUPPLIED)

To install a ZipScreen, the following non-stocked items are required:

- Fasteners for Box/Open Brackets/Hardware (ensure appropriate fasteners are used to suit application)
- Trims to conceal packing (if required)

SHADE ITEMS REQUIRED

BOX

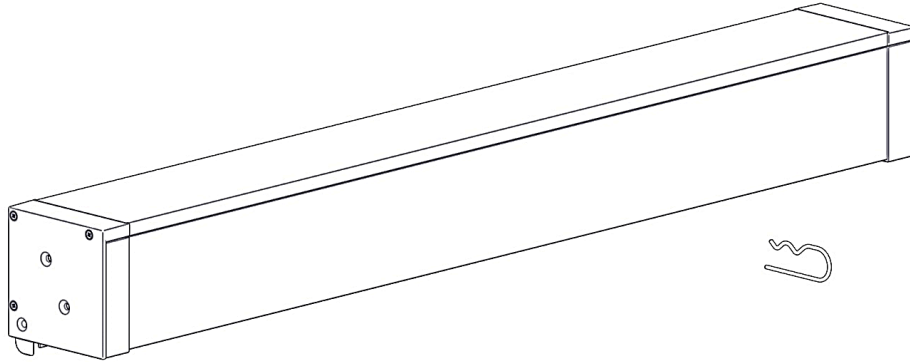

NOTE: 2 x R-Clips required for Spring Operated Shades

or

FASCIA

Fascia Bracket (RE03-0101-xxx000) may be required as a centre support for larger spans

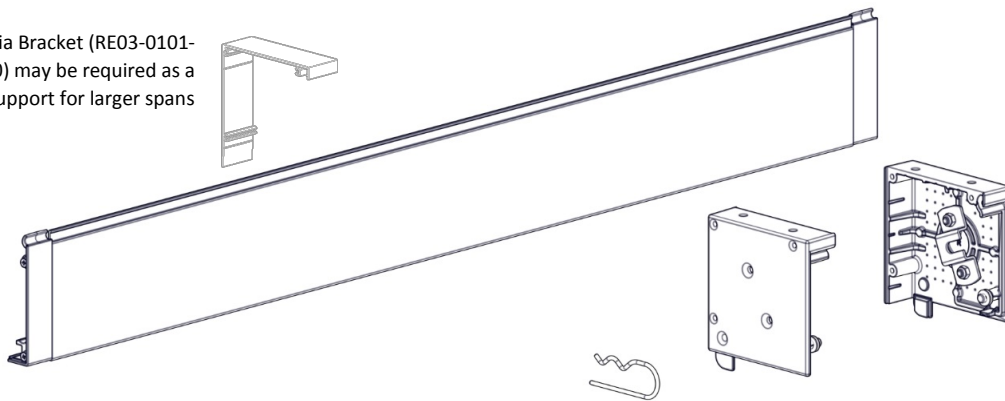

NOTE: 2 x R-Clips required for Spring Operated Shades

or

OPEN BRACKETS

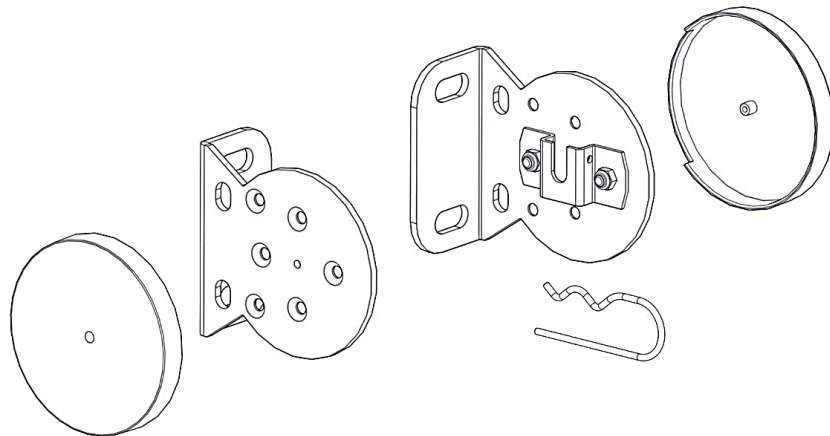

NOTE: 2 x R-Clips required for Spring Operated Shades

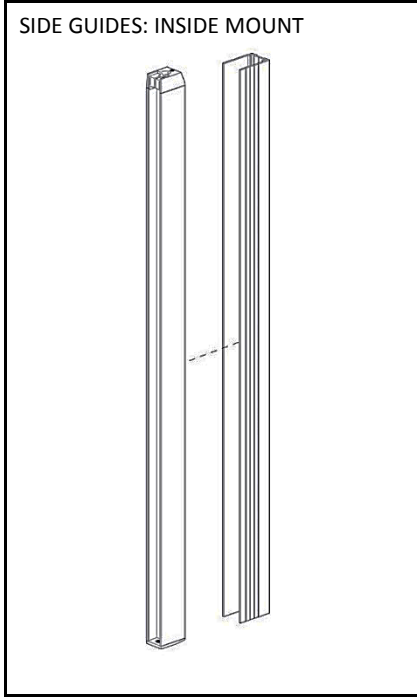

or

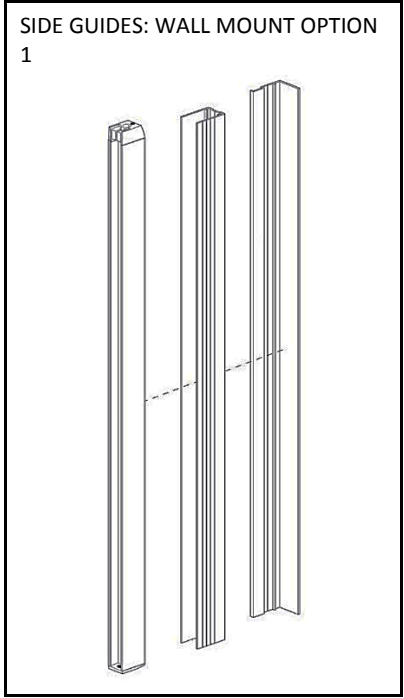

or

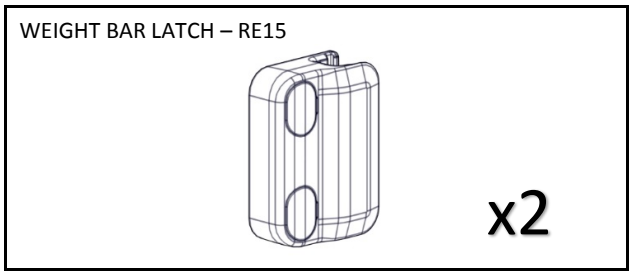
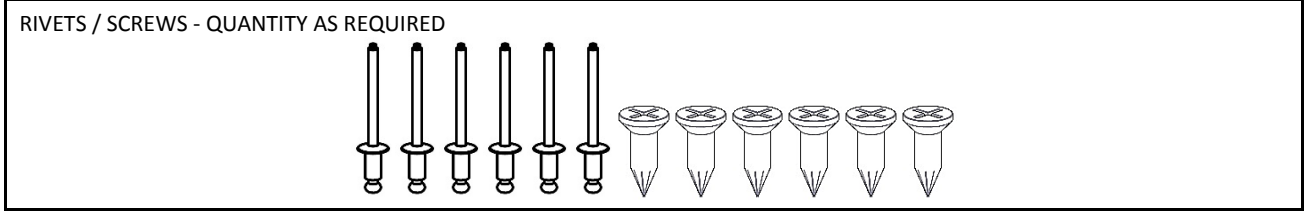
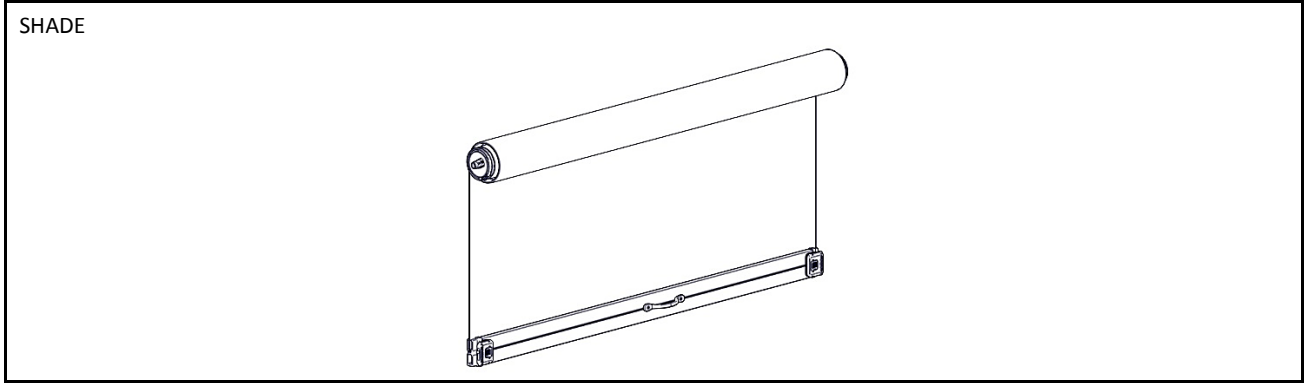
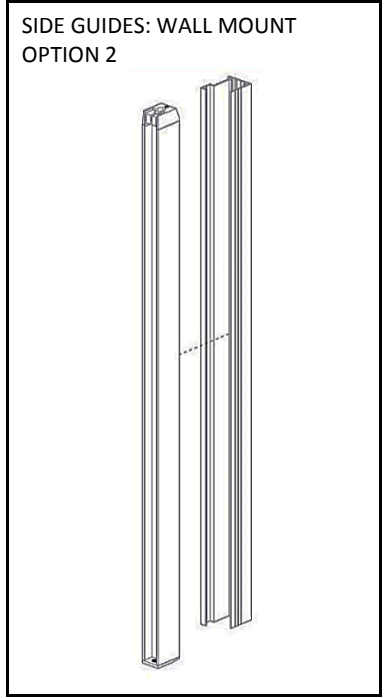

or

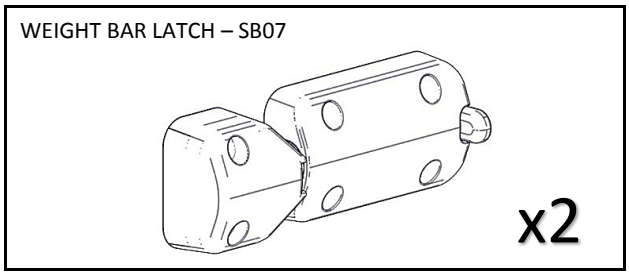

SECTION 2 – INSTALLATION

PART A – PREPARING INSTALLATION SPACE

STEP 1 – CHECK FOR OBSTRUCTIONS

Check for any obstructions that may interfere in installation.

E.g. If there is an architrave at the bottom of a post that the Zipscreen is to be installed into, ensure you prepare the space for the installation.

This may mean that the installer needs to cut into the architrave to make room for the side rails.

STEP 2 – CHECK TOP OF INSTALLATION IS LEVEL

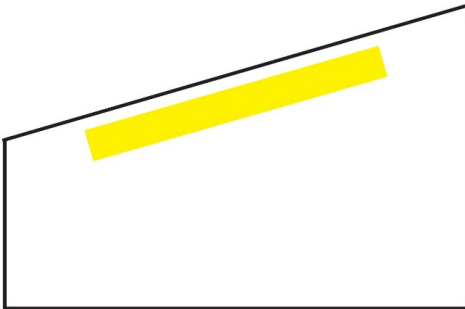

If un-even go to step 3
If level go to step 4

STEP 3 – PACK AND LEVEL TOP OF INSTALLATION TO SMALLEST DROP DIMENSION

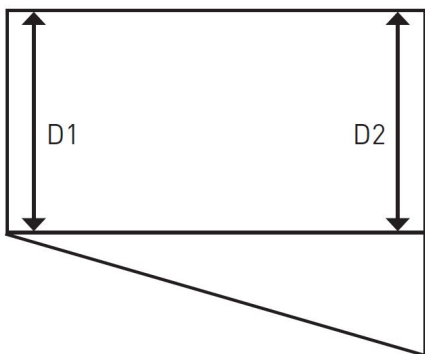
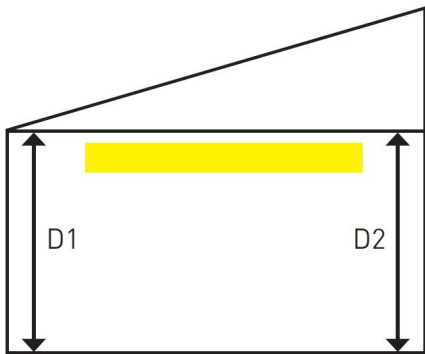

D = Drop of Shade

NOTE: In some instances, when the drop is level D1 & D2 will not be equal as there is an uneven ground.

Ensure the smallest value of D1 & D2 = Shade Drop (D specified in initial measurement)

Where there is uneven ground, side rails may be supplied in different lengths for a better aesthetical finish to shade

STEP 4 – CHECK HORIZONTAL INSTALLATION DIMENSION AT TOP, CENTER & BOTTOM

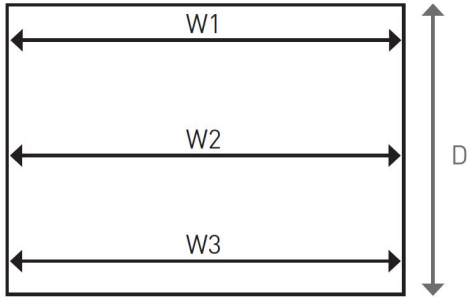

W = Width of shade

If W1, W2, & W3 are equal or within 0.4" of each other, proceed to Step 5 for Inside mount applications, or Step 6 for Wall mount applications.

If W1, W2, & W3 are not equal or within 0.4" of each other, review the scenarios outlined in Step 4 and determine if and where packing is required.

When using wall mount U Mounting Rail, W3 must be less than or equal to W1.

The following steps describe scenarios when using L Fastener Rail in application.

STEP 5 – PACK INSTALLATION WIDTH TO SHADE WIDTH MEASUREMENT

SCENARIO

PACKING DETAILS

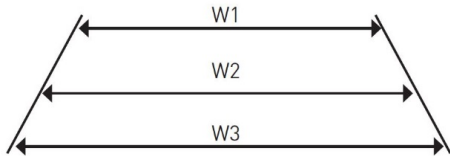

W3 is greater than W1 and W2

Determine dimension x on each side

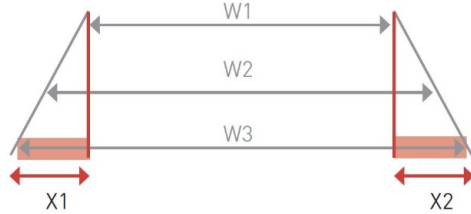

If X1 or X2 is less than 0.40", no packing necessary (however, a square space will provide greater flexibility with the rest of the installation).

If x is equal to or greater than 0.40", packing is required. Pack out the largest dimensions (W3) to be within 0.4" of the smallest dimension (W1).

Ensure W1 = Shade Width

(Shade width is specified in initial check and measure)

Proceed to Step 6 for Inside mount applications, or Step 7 for Wall mount applications

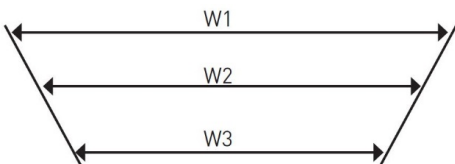

W1 is greater than W2 and W3

Pack space so that the top is equal to or within 0.40" of the smallest dimension (W3)

Ensure W3 = Shade Width

(Shade width is specified in initial check and measure)

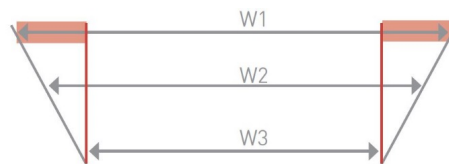

Proceed to Step 6 for Inside mount applications, or Step 7 for Wall mount applications

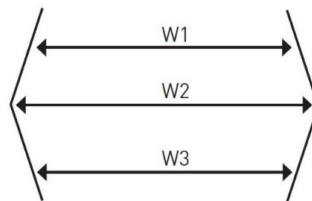
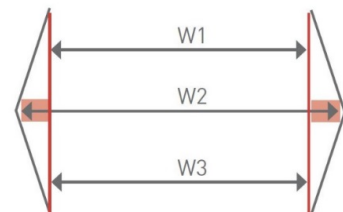
 <p>W2 is greater than W1 and W3</p>	<p>Pack space so largest dimension (W2) to be equal to or within 0.40" of smallest dimension (W1 or W3). Ensure smallest dimension = Shade Width (Shade width is specified in initial check and measure)</p>  <p>If W1 and W3 sizes are different, minor packing may also be required at these locations.</p> <p>Proceed to Step 6 for Inside mount applications, or Step 7 for Wall mount applications</p>
---	---

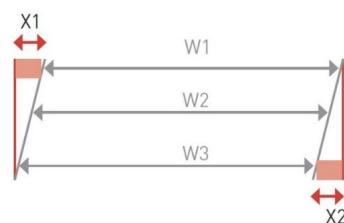
STEP 6 – CHECK SIDES OF INSTALLATION ARE LEVEL (FOR INSIDE MOUNT APPLICATIONS ONLY)	
SCENARIO	PACKING DETAILS
 <p>If un-even refer to packing evaluation on the right If level go to Step 7.</p>	<p>Determine dimension x on each side</p>  <p>If X1 or X2 is less than 0.40", no packing necessary (however, a square space will provide greater flexibility with the rest of the installation).</p> <p>If X1 or X2 is equal to or greater than 0.40", packing is required. Pack out the sides so they are level or within 0.40" of W1.</p> <p>Ensure the finished W1 width = Shade Width (Shade width is specified in initial check and measure)</p>

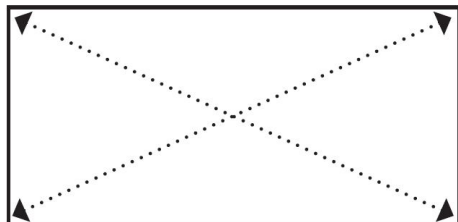
STEP 7 – CHECK AND ENSURE THE INSTALLATION SPACE IS LEVEL & SQUARE	
	



PART B – SPRING PRE-TENSIONING

STEP 1 – IDENTIFY NUMBER OF PRE-TURNS REQUIRED FOR SHADE SIZE

78mm TUBE [F56 Weight Bar]

Wraps	Drop (ft)	WIDTH (ft)																System								
		3.0			5.0			7.0			9.0			10.0			12.0				14.0			16.0		
2	2.0	5	7	10	11	13	10	11	13	14	9	10	10	11	12	12	13	14	8	8	8	9	9	10	10	
2		5	7	10	11	13	10	11	13	14	9	10	10	11	12	13	13	14	8	8	9	9	9	9	10	
3		5	7	10	11	13	10	12	13	14	9	10	10	11	12	13	13	14	8	8	9	9	9	9	10	
3	3.0	5	7	11	12	13	10	12	13	14	9	10	10	11	12	13	13	14	8	8	9	9	9	9	10	
3		5	7	11	12	14	10	12	13	14	9	10	11	11	12	13	14	8	8	8	9	9	9	10	10	
4		5	7	11	12	14	10	12	13	8	9	10	11	11	12	13	14	8	8	8	9	9	9	10	10	
4	4.0	5	7	11	12	14	11	12	13	8	9	10	11	11	12	13	14	8	8	8	9	9	9	10	10	
5		6	7	11	12	14	11	12	13	8	9	10	11	12	12	13	14	8	8	9	9	9	9	10	10	
5		6	7	11	12	14	11	12	13	9	9	10	11	12	12	13	14	8	8	9	9	9	9	10	10	
5	5.0	6	7	11	12	14	11	12	13	9	9	10	11	12	13	13	14	8	8	9	9	9	9	10	10	
6		6	7	11	12	14	11	12	14	9	9	10	11	12	13	13	14	8	8	9	9	9	9	10	10	
6		6	7	11	12	14	11	12	14	9	10	10	11	12	13	13	14	8	8	9	9	9	10	10	10	
6	6.0	6	7	11	12	14	11	12	14	9	10	10	11	12	13	14	14	8	8	9	9	9	10	10	10	
7		6	7	11	12	14	11	12	14	9	10	10	11	12	13	14	14	8	8	9	9	9	10	10	11	
7		6	7	11	12	14	11	13	14	9	10	11	11	12	13	14	15	8	9	9	9	9	10	10	11	
7	7.0	6	7	11	13	15	11	13	14	9	10	11	11	12	13	14	15	8	9	9	9	9	10	10	11	
8		6	7	12	13	15	11	13	14	9	10	11	11	12	13	14	8	8	9	9	9	9	10	10	11	
8		6	7	12	13	15	11	13	14	9	10	11	12	12	13	14	8	8	9	9	9	10	10	10	11	
8	8.0	6	7	12	13	15	11	13	14	9	10	11	12	12	13	14	8	8	9	9	9	10	10	10		
9		6	7	12	13	15	11	13	14	9	10	11	12	13	13	14	8	8	9	9	9	10	10			
9		6	7	12	13	10	12	13	14	9	10	11	12	13	13	14	8	8	9	9	9	10				
9	9.0	6	8	12	13	10	12	13	15	9	10	11	12	13	13	14	8	8	9	9	9					
10		6	8	12	13	10	12	13	15	9	10	11	12	13	14	14	8	8	9							
10		6	8	12	13	10	12	13	15	9	10	11	12	13	14	15	8	9								
10	10.0	6	8	12	13	10	12	13	15	9	10	11	12	13	14	15	8									
11		6	8	12	13	10	12	13	15	9	10	11	12	13	14	15	8									
11		6	8	12	13	10	12	13	15	10	10	11	12	13	14	15										
11	11.0	6	8	12	13	11	12	14	15	10	10	11	12	13	14	15										
12		6	8	12	13	11	12	14	9	10	11	11	12	13	14	15										
12		6	8	12	14	11	12	14	9	10	11	11	12	13	14											
12	12.0	6	8	13	14	11	12	14	9	10	11	12	12	13	14											
13		6	8	13	14	11	12	14	9	10	11	12	12	13												
13		6	8	13	14	11	12	14	9	10	11	12	13	13												
13	13.0	6	8	13	14	11	12	14	9	10	11	12	13	14												
14		6	8	13	14	11	12	14	9	10	11	12	13													
14		7	8	13	14	11	13	14	9	10	11	12	13													
14	14.0	7	8	13	14	11	13	14	9	10	11	12	13													

Parameters: 24.17 oz/yd² fabric

LEGEND	DESCRIPTION	TOTAL No. of WRAPS + PRE-TURNS MUST NOT EXCEED
	RE01 Short Spring	26
	RE01 Light Spring	44
	RE01 Standard Spring	38
	RE01 Heavy Spring	31
	RE01 Extra Heavy Spring	23
	78mm Aluminium Tube Optimum Performance	
	78mm Steel Tube Optimum Performance	
	Cannot be achieved - outside product specifications	

The above charts are indicative only and indicate the minimum number of pre-turns required. Due to variances in fabric weights, additional ballast weight and installations the optimum number of pre-turns will vary. Pre-turns can be adjusted during installation. Refer to Section 2, Part F, Steps 7 – 10.

78mm TUBE [F56 Weight Bar + 12mm Round Ballast]

Wraps	WIDTH (ft)																System								
	Drop (ft)	3.0			5.0			7.0			9.0			10.0				12.0			14.0			16.0	
2	2.0	9	11	17	19	22	22	22	21	23	26	28	17	19	20	21	22	24	25	14	14	15	16	16	Box or Open Blind
2		9	11	18	19	22	22	22	22	24	26	28	17	19	20	21	22	24	13	14	14	15	16	16	
3		9	11	18	19	23	23	20	22	24	26	28	18	19	20	21	23	24	13	14	15	15	16		
3	3.0	9	11	18	20	23	23	20	22	24	26	28	18	19	20	22	23	12	13	14	15	15			
3		9	11	18	20	23	23	20	22	24	26	29	18	19	20	22	23	12	13	14	15	15			
4		9	11	18	20	23	23	20	22	24	27	29	18	19	21	22	12	13	14	14	15				
4	4.0	9	12	18	20	23	23	20	22	25	27	17	18	19	21	22	12	13	14	14					
5		9	12	18	20	23	23	20	22	25	27	17	18	20	21	22	12	13	14						
5		9	12	19	20	24	24	20	23	25	27	17	18	20	21	12	12	13	14						
5	5.0	9	12	19	20	24	24	21	23	25	27	17	19	20	21	12	13	13							
6		10	12	19	21	24	24	21	23	25	28	17	19	20	11	12	13								
6		10	12	19	21	24	24	21	23	25	28	17	19	20	11	12	13								
6	6.0	10	12	19	21	24	24	21	23	26	16	18	19	20	11	12									
7		10	12	19	21	24	24	21	23	26	16	18	19	11	11	12									
7		10	12	19	21	25	25	21	24	26	16	18	19	11	12										
7	7.0	10	12	19	21	25	25	21	24	26	17	18	19	11											
8		10	12	20	21	25	25	21	24	15	17	18	10	11											
8		10	12	20	21	25	25	22	24	15	17	18	10												
8	8.0	10	12	20	22	25	25	22	24	15	17	18	10												
9		10	12	20	22	25	25	22	24	16	17	10													
9		10	13	20	22	25	25	22	24	16	17	10													
9	9.0	10		20	22	26	25	22	14	16	17														
10		10		20	22	26	25	22	14	16	9														
10		10		20	22	26	25	22	14	16															
10	10.0	10		21	22	26	20	23	15	16															
11		10		21	22	26	20	23	15	16															
11		11		21	23	26	20	23	15																
11	11.0			21	23	27	20	13	15																
12				21	23	27	20	13	15																
12				21	23	27	21	13	15																
12	12.0			21	23	27	21	14																	
13				21	23	27	21	14																	
13				21	23	18	21	14																	
13	13.0			22	23	18	12																		
14				22	24	19	12																		
14				22	24	19	12																		

Parameters: 24.17 oz/yd² fabric

LEGEND	DESCRIPTION	TOTAL No. of WRAPS + PRE-TURNS MUST NOT EXCEED
	RE01 Short Spring	26
	RE01 Light Spring	44
	RE01 Standard Spring	38
	RE01 Heavy Spring	31
	RE01 Extra Heavy Spring	23
	78mm Aluminium Tube Optimum Performance	
	78mm Steel Tube Optimum Performance	
	Cannot be achieved - outside product specifications	

The above charts are indicative only and indicate the minimum number of pre-turns required. Due to variances in fabric weights, additional ballast weight and installations the optimum number of pre-turns will vary. Pre-turns can be adjusted during installation. Refer to Section 2, Part F, Steps 7 – 10.

78mm TUBE [HD Hem Bar]

Wraps	Drop (ft)	WIDTH (ft)																System								
		3.0			5.0			7.0			9.0			10.0			12.0				14.0			16.0		
2	2.0	8	10	15	16	19	22	17	18	20	22	14	15	16	17	18	19	20	21	22	23	12	13	14	14	Box or Open Blind
2		8	10	15	17	19	22	17	19	20	22	14	15	16	17	18	19	21	22	23	13	13	13	14	14	
3		8	10	15	17	20	22	17	19	21	23	14	15	16	17	19	20	21	22	23	13	13	13	14	14	
3	3.0	8	10	15	17	20	22	17	19	21	23	14	15	16	18	19	20	21	22	23	13	13	13	14	14	
3		8	10	16	17	20	23	17	19	21	23	14	15	17	18	19	20	21	22	23	13	13	13	14	15	
4		8	10	16	17	20	23	17	19	21	23	14	16	17	18	19	20	21	22	23	13	13	13	14	15	
4	4.0	8	10	16	17	20	23	17	19	21	23	15	16	17	18	19	20	21	22	23	13	13	14	14	15	
5		8	10	16	17	20	23	18	19	21	23	15	16	17	18	19	20	21	22	23	13	13	14	14		
5		8	10	16	17	20	23	18	20	22	24	15	16	17	18	19	20	22	23	13	13	14				
5	5.0	8	10	16	18	21	23	18	20	22	24	15	16	17	18	19	21	11	12	13	13					
6		8	10	16	18	21	24	18	20	22	24	15	16	17	18	20	21	12	12	13						
6		8	10	16	18	21	24	18	20	22	24	15	16	17	19	20	21	12	12	13						
6	6.0	8	10	16	18	21	24	18	20	22	24	15	16	18	19	20	11	12	12							
7		8	11	17	18	21	24	18	20	22	24	15	16	18	19	20	11	12								
7		8	11	17	18	21	24	18	20	22	24	15	17	18	19	11	11	12								
7	7.0	9	11	17	18	21	24	18	21	23	24	15	17	18	19	11	11									
8		9	11	17	18	22	24	19	21	23	24	16	17	18	19	11										
8		9	11	17	19	22	24	19	21	23	24	16	17	18	10	11										
8	8.0	9	11	17	19	22	24	19	21	23	24	16	17	18	10											
9		9	11	17	19	22	24	19	21	23	24	16	17	10												
9		9	11	17	19	22	24	19	21	23	24	16	17	10												
9	9.0	9	11	17	19	22	24	19	21	23	24	16	17													
10		9	11	18	19	22	24	19	21	24	24	16	17													
10		9	11	18	19	22	24	19	22	24	24	16														
10	10.0	9	11	18	19	23	24	20	22	24	24	16														
11		9		18	19	23	24	20	22	24	24	16														
11		9		18	20	23	24	20	22	24	24	16														
11	11.0	9		18	20	23	24	20	22	24	24	16														
12		9		18	20	23	24	20	22	24	24	16														
12		9		18	20	23	24	20	22	24	24	16														
12	12.0	9		18	20	23	24	20	22	24	24	16														
13				18	20	23	24	20	22	24	24	16														
13				19	20	24	24	20	22	24	24	16														
13	13.0			19	20	24	24	20	22	24	24	16														
14				19	20	24	24	20	22	24	24	16														
14				19	21	24	24	20	22	24	24	16														

Parameters: 24.17 oz/yd² fabric

LEGEND	DESCRIPTION	TOTAL No. of WRAPS + PRE-TURNS MUST NOT EXCEED
	RE01 Short Spring	26
	RE01 Light Spring	44
	RE01 Standard Spring	38
	RE01 Heavy Spring	31
	RE01 Extra Heavy Spring	23
	78mm Aluminium Tube Optimum Performance	
	78mm Steel Tube Optimum Performance	
	Cannot be achieved - outside product specifications	

The above charts are indicative only and indicate the minimum number of pre-turns required. Due to variances in fabric weights, additional ballast weight and installations the optimum number of pre-turns will vary. Pre-turns can be adjusted during installation.

STEP 2 – LOCK SPRING AT SPRING END

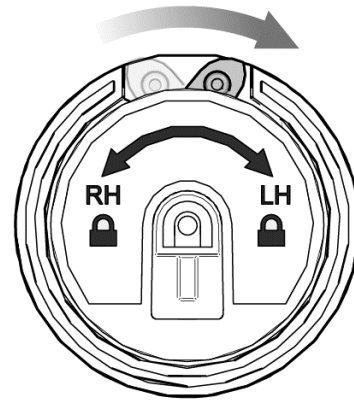
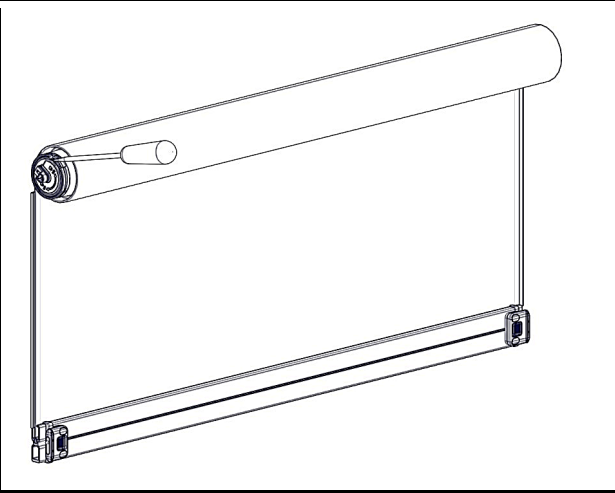

LEFT HAND LOCKED

STEP 3 – ENGAGE SPANNER ONTO PRE-TENSION HEAD

Slide Down to Engage

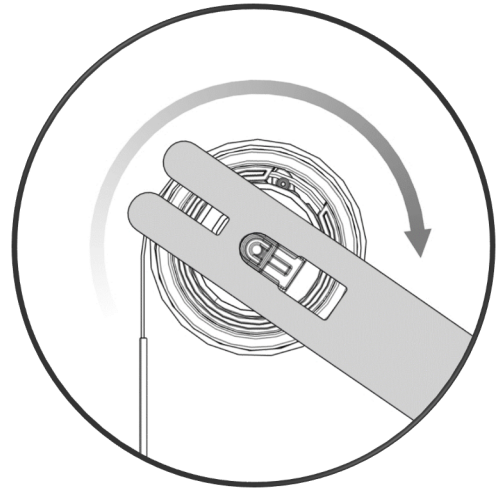
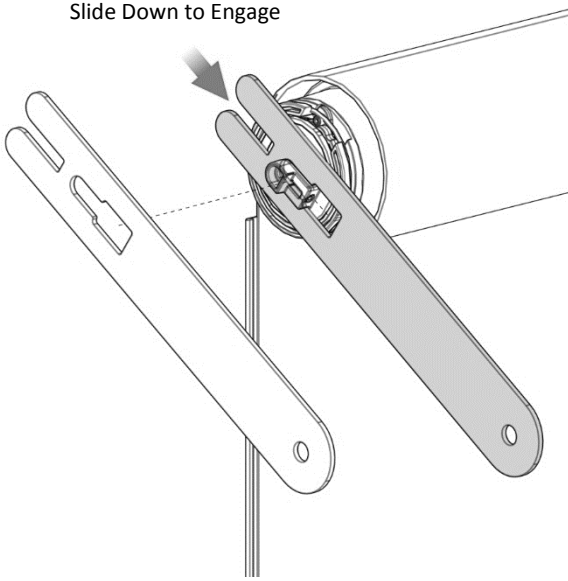

STEP 4 – PRE-TURN SPRING DIRECTION INDICATED ON LABEL

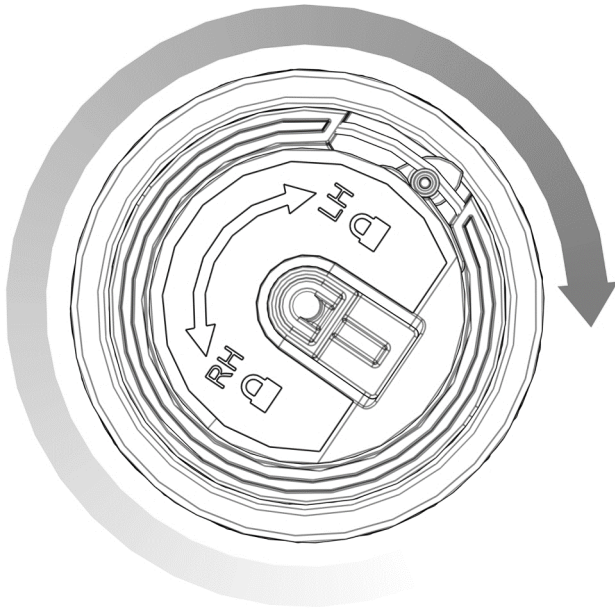

LEFT HAND
Pre-Tension Clockwise

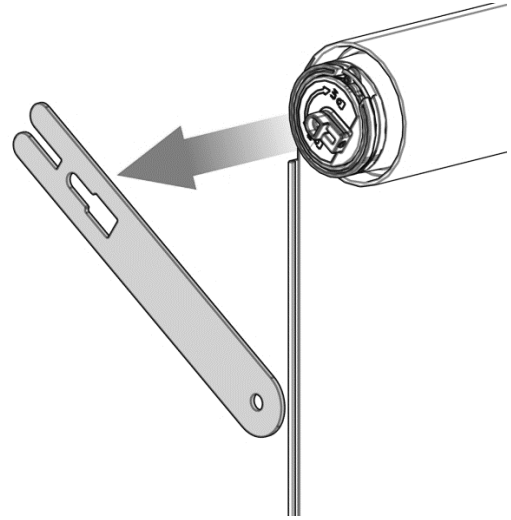

Remove Spanner

Pre-turn spring for number of times indicated in Section 2, Part B.
A click will be heard for each turn

PART C – BOX INSTALLATION

STEP 1 – INSTALL BOX TO WALL/CEILING

WALL MOUNT

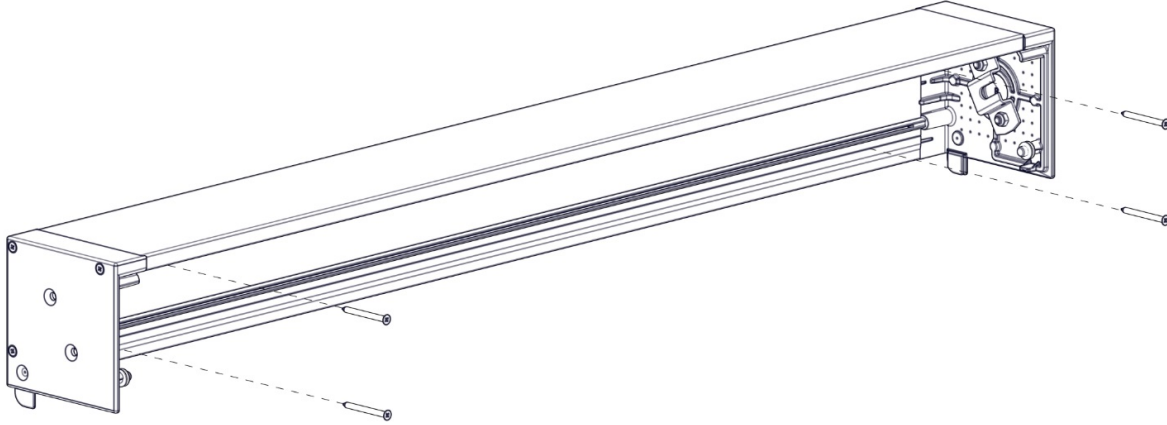

Note: Use appropriate fasteners to suit application
Ensure Box is Aligned and Level

CEILING MOUNT

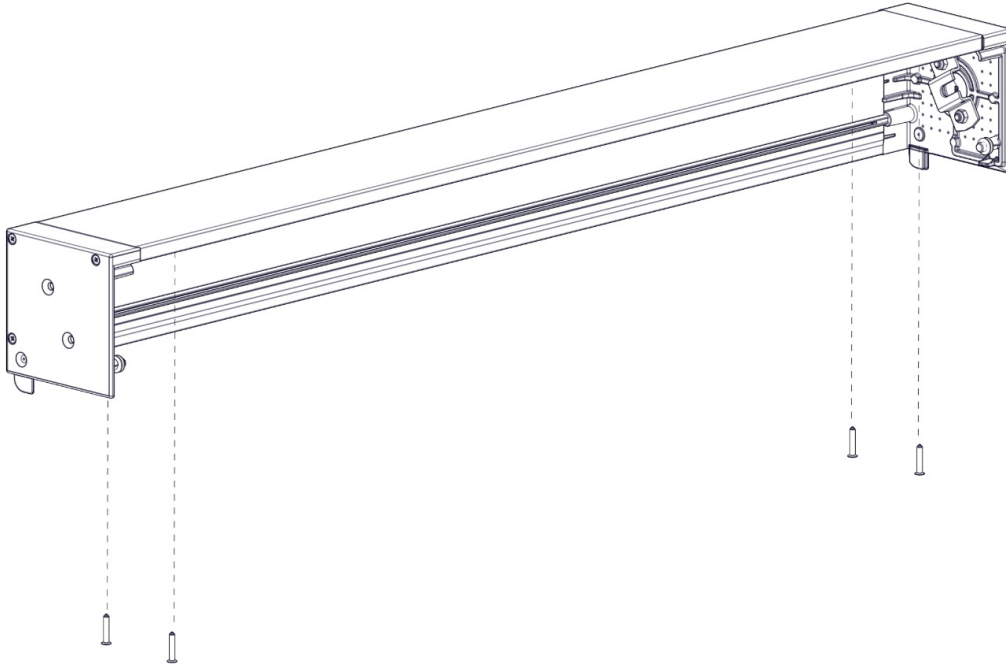

Note: Use appropriate fasteners to suit application
Ensure Box is Aligned and Level

INSIDE MOUNT

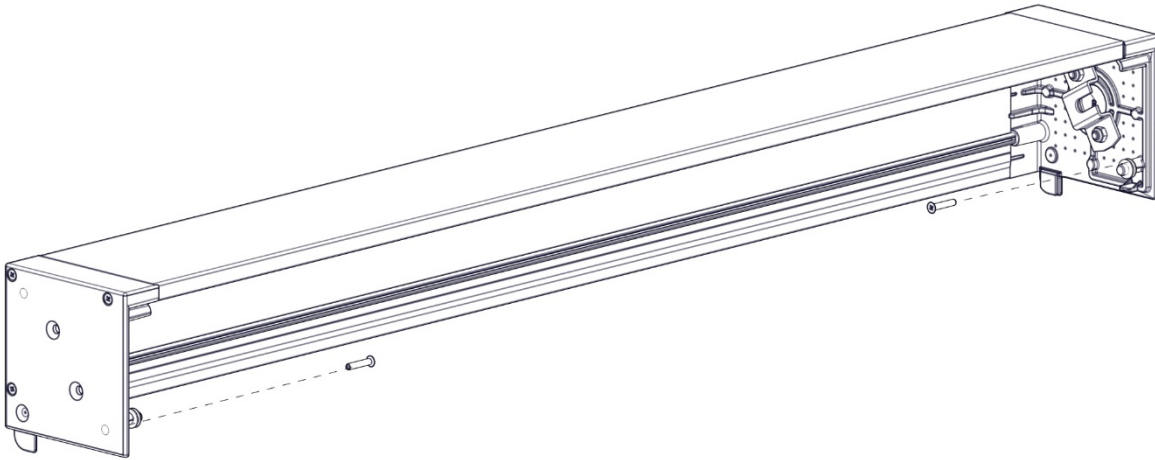

Note: Use appropriate fasteners to suit application
Ensure Box is Aligned and Level

PART D – FASCIA INSTALLATION

STEP 1 – INSTALL END PLATES TO WALL/CEILING USING APPROPRIATE FASTENERS TO SUIT APPLICATION

WALL MOUNT

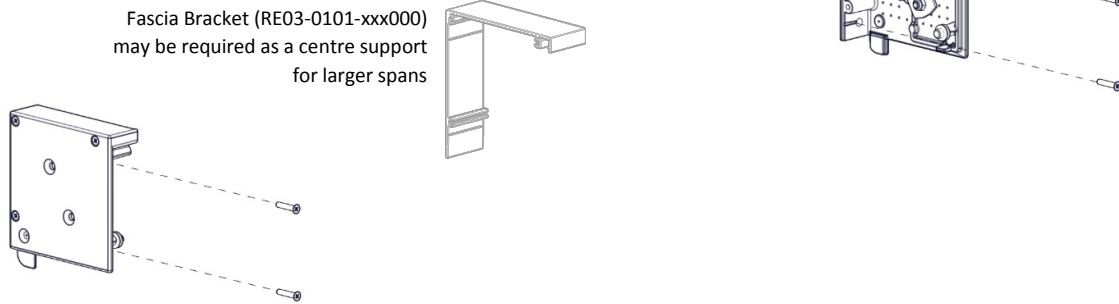

Note: Use appropriate fasteners to suit application
Ensure End Plates are Aligned and Level
Measure brackets end to end to confirm measurement is correct

CEILING MOUNT

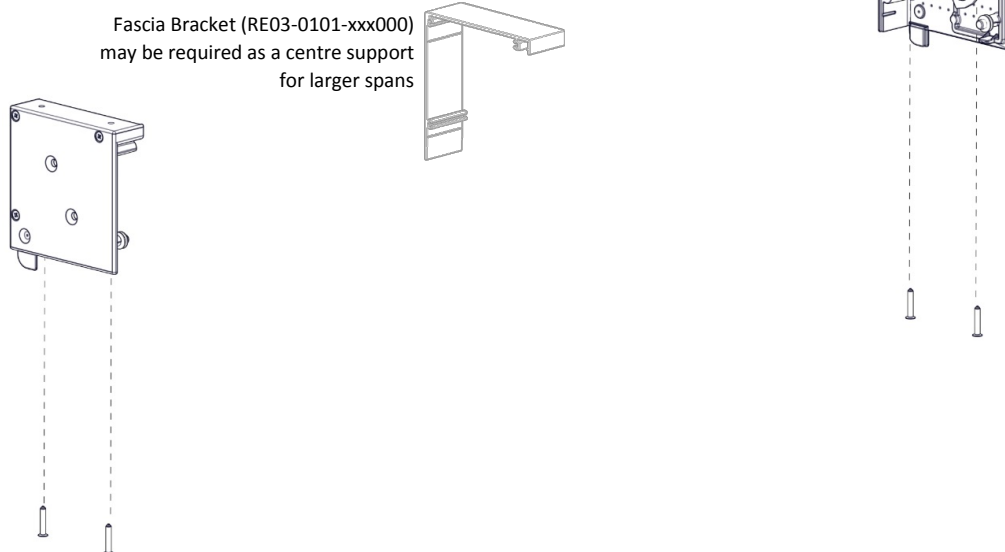

Note: Use appropriate fasteners to suit application
Ensure End Plates are Aligned and Level
Measure brackets end to end to confirm measurement is correct

INSIDE MOUNT

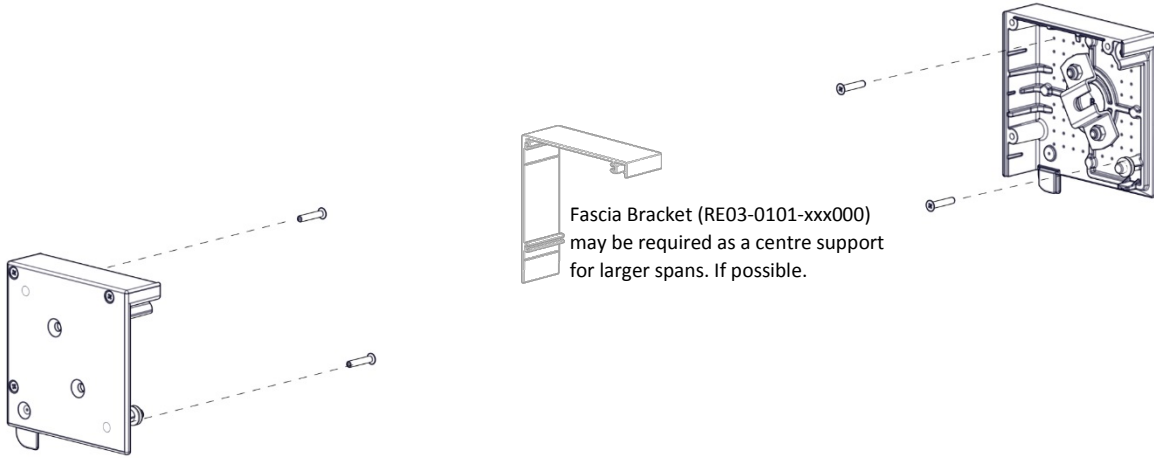

Fascia Bracket (RE03-0101-xxx000)
may be required as a centre support
for larger spans. If possible.

Note: Use appropriate fasteners to suit application
Ensure End Plates are aligned and level
Measure brackets end to end to confirm measurement is correct

PART E – OPEN BRACKET INSTALLATION

STEP 1 – INSTALL BRACKETS TO WALL/CEILING USING APPROPRIATE FASTENERS TO SUIT APPLICATION

WALL MOUNT

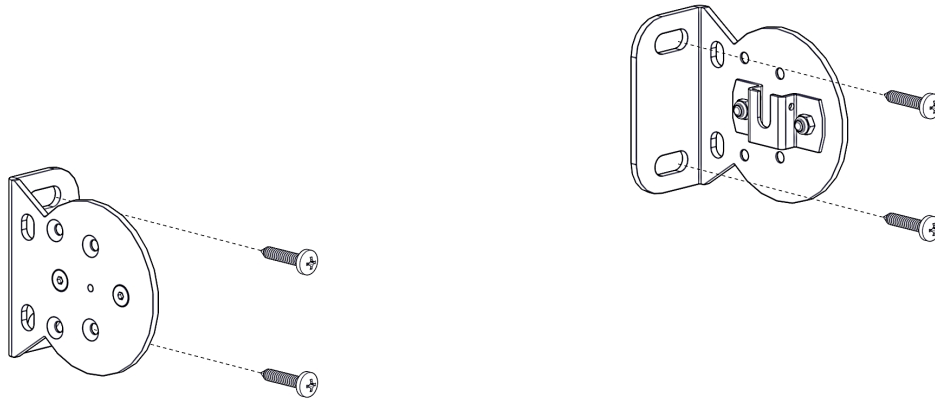

Note: Use appropriate fasteners to suit application
Ensure Box is Aligned and Level
Ensure brackets are aligned and level
Measure brackets end to end to confirm measurement is correct

CEILING MOUNT

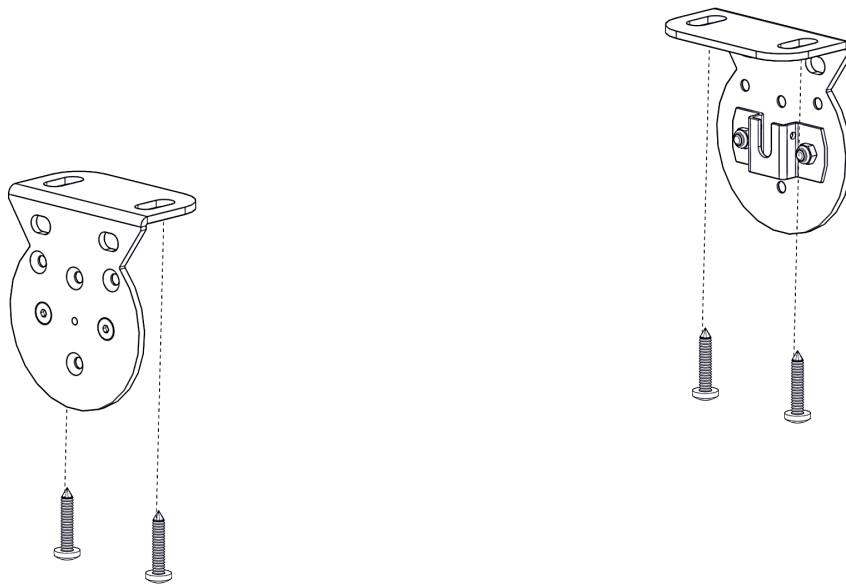

Note: Use appropriate fasteners to suit application
Ensure Box is Aligned and Level
Ensure brackets are aligned and level
Measure brackets end to end to confirm measurement is correct

INSIDE MOUNT

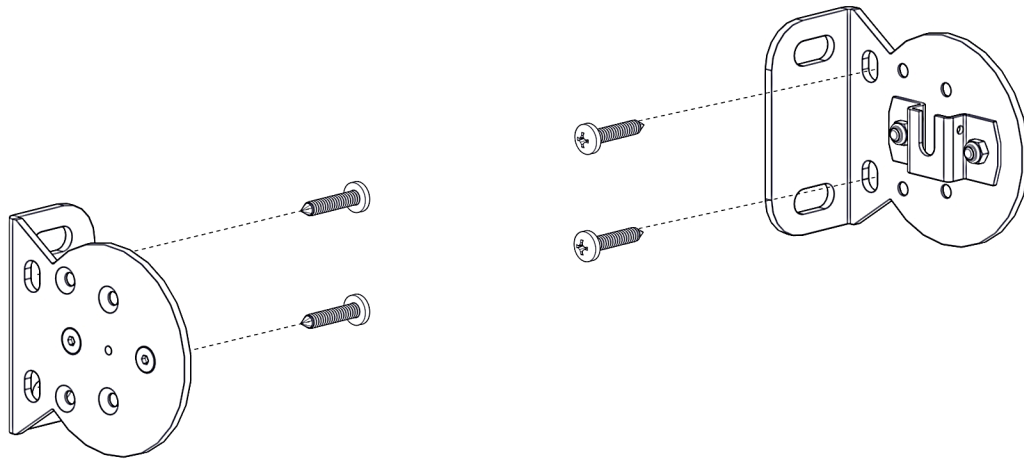

Note: Use appropriate fasteners to suit application
Ensure Box is Aligned and Level
Ensure brackets are aligned and level
Measure brackets end to end to confirm measurement is correct

PART F – SHADE INSTALLATION

STEP 4 – INSERT SHADE INTO BOX

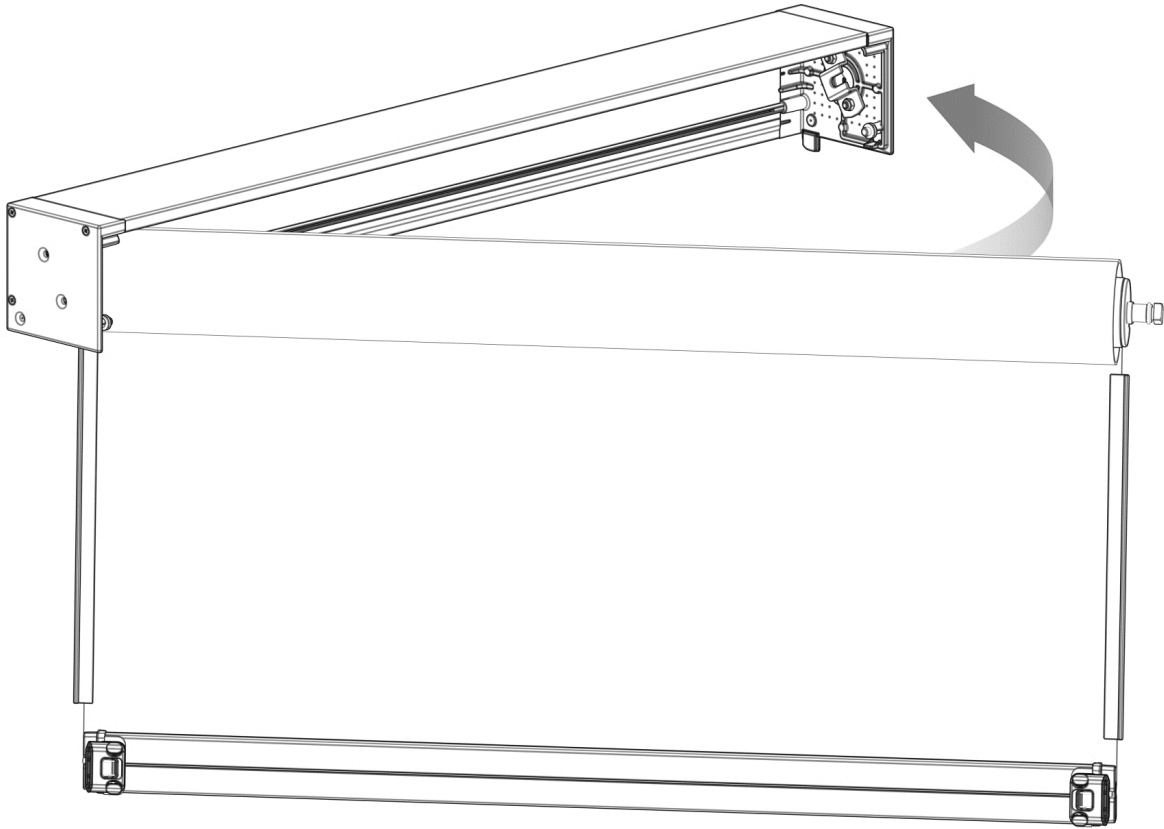

Ensure control is installed securely

STEP 5 – INSERT R-CLIP ONTO IDLER ADAPTER

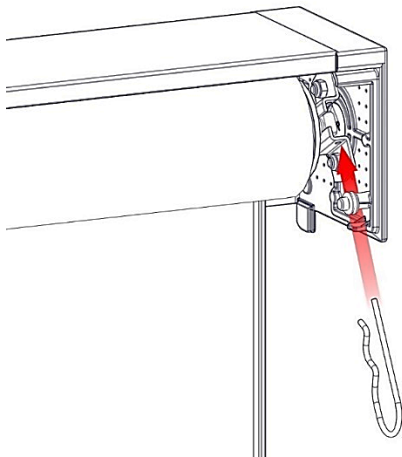

Ensure pin is clipped in securely

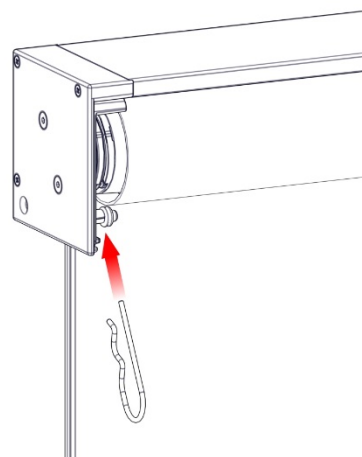

SPRING ONLY: Insert R-clip at spring end

STEP 6 – UNLOCK PRE-TENSION HEAD AT SPRING END (FOR SPRING ONLY)

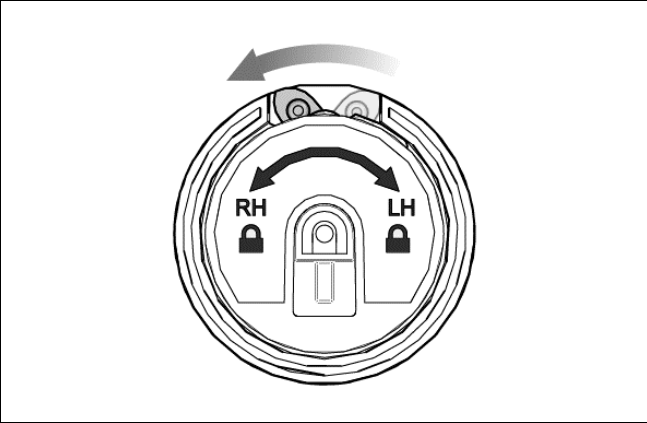
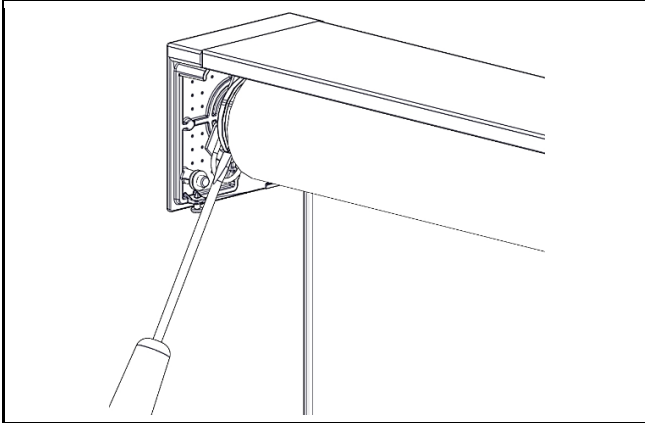

STEP 7 – FEED THROUGH MOTOR CABLE (FOR MOTOR ONLY)

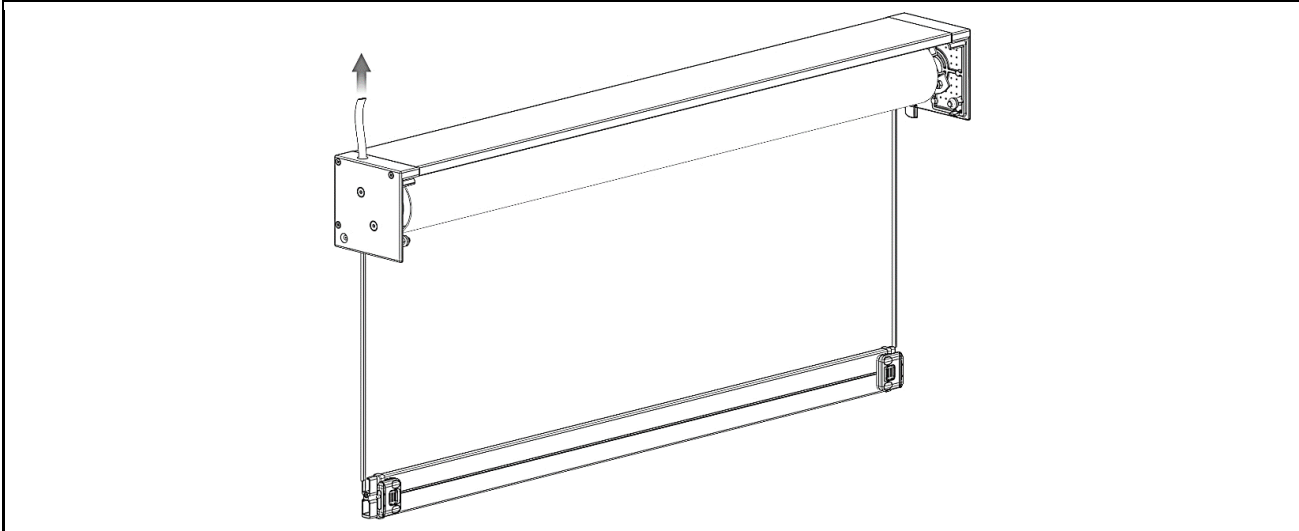

STEP 8 – RUN SHADE DOWN + CENTER

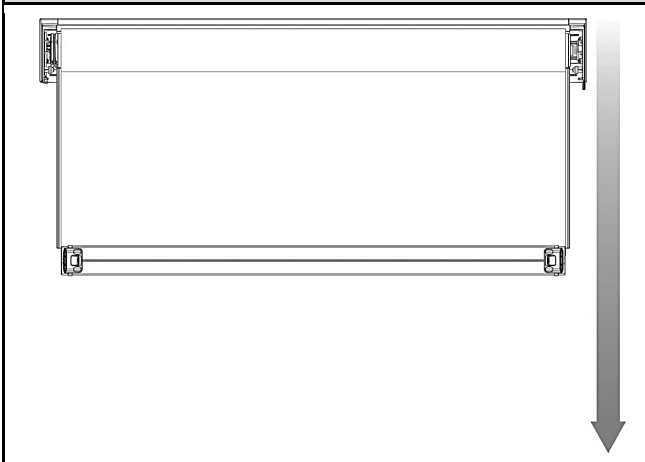

STEP 9 – TEST SHADE OPERATION

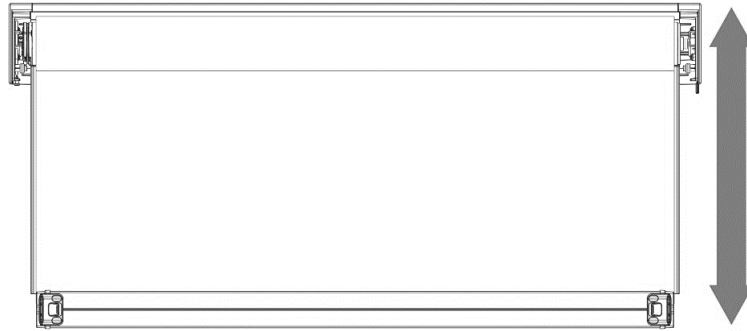

For spring operation, shade should creep up slowly when pulled down.
If shade does not creep up, add more pre-turns. Refer steps 7 - 10
For motor operation, ensure wiring is correct and motor is operating correctly.
For gear operation, ensure operation is smooth.
Once shade is operating correctly, proceed to SECTION 2 / Part G.

STEP 10 – TO ADJUST PRE-TURNS LOCK PRE-TENSION HEAD AT SPRING END (FOR SPRING ONLY)

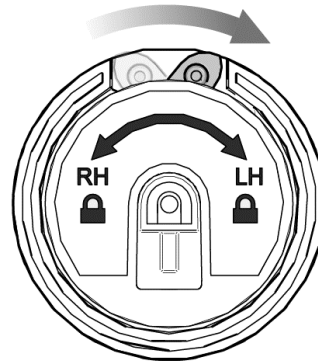
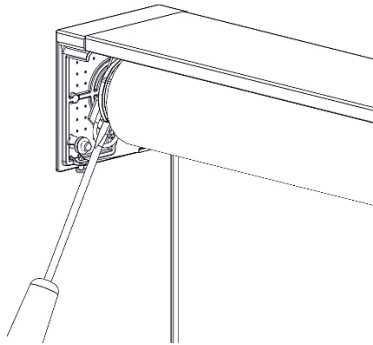

STEP 11 – DISENGAGE PRE-TENSION IDLER AT SPRING END FROM ADAPTER (FOR SPRING ONLY)

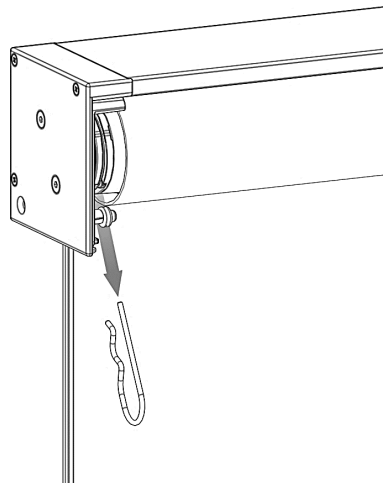

STEP 12 – ADD ADDITIONAL PRE-TURNS REQUIRED (FOR SPRING ONLY)

Add extra number of pre-tensions required.
Refer to Section 2, Step 3-4 for details.
Note: Gradually increase the number of pre-turns required.

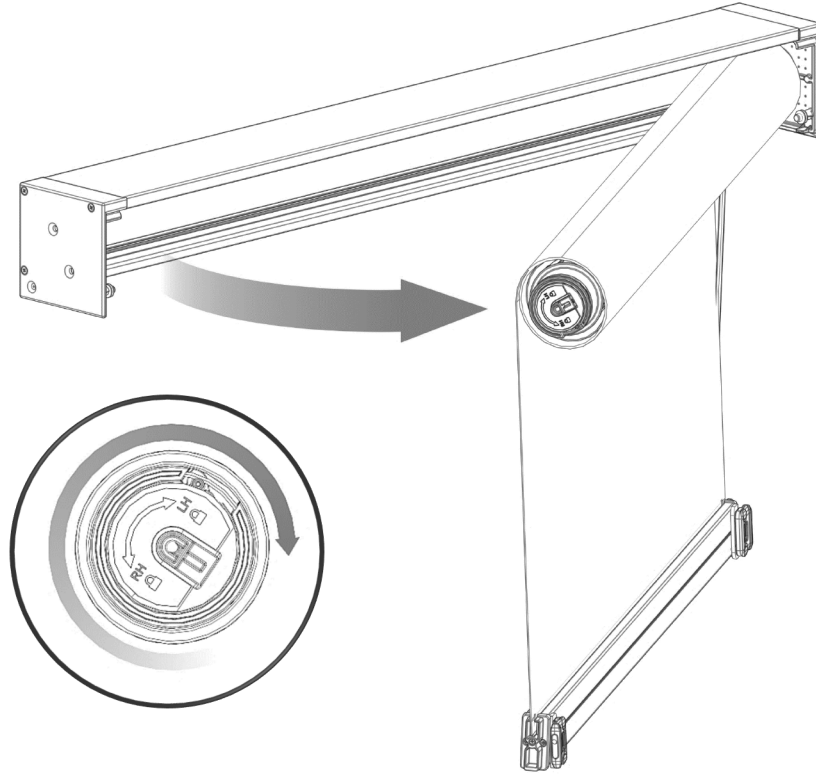

STEP 13 – RE-INSTALL AND TEST SHADE (FOR SPRING ONLY)

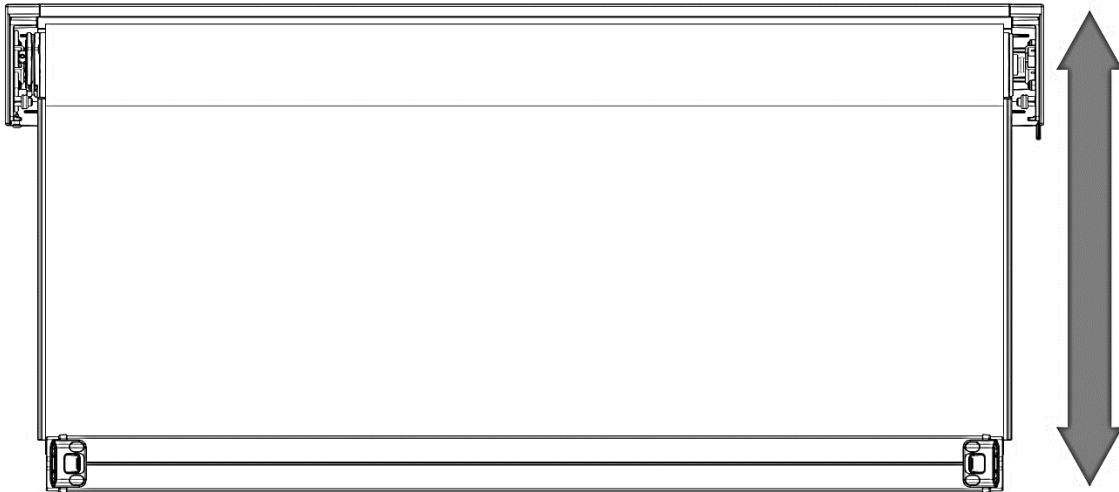

Repeat steps 4 - 7
If too many pre-turns are added, the shade will automatically raise when installed.
Repeat steps 7 – 10 until shade is operating as required.

PART G – SIDE GUIDE INSTALLATION

STEP 1 – MARK OUT SIDE GUIDE POSITION AND ALIGN RAIL (FOR OPEN BRACKET ONLY)

INSIDE MOUNT

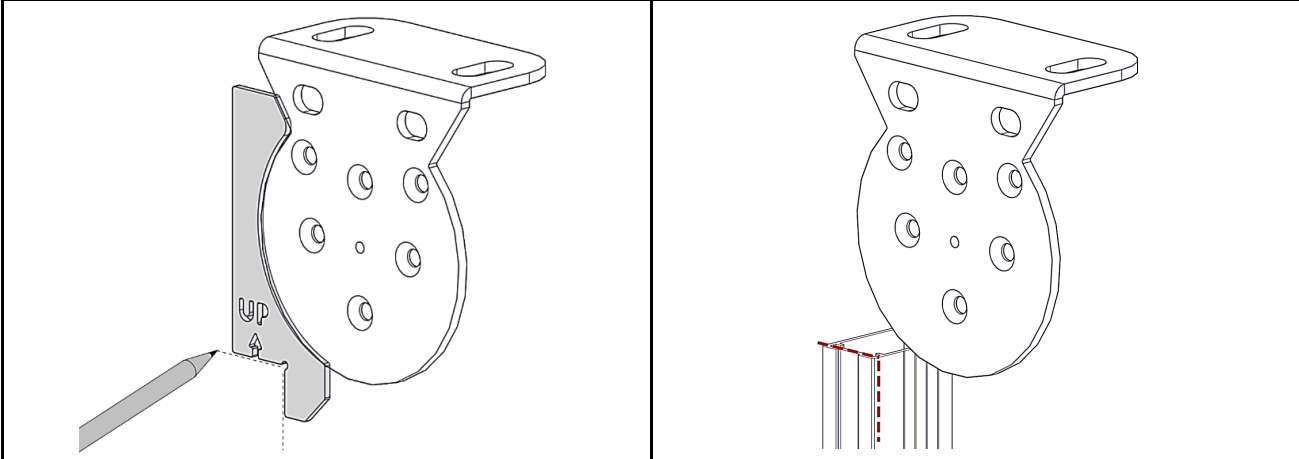

Note: Use Open Bracket Template (RE01-3012-033000) to assist

WALL MOUNT

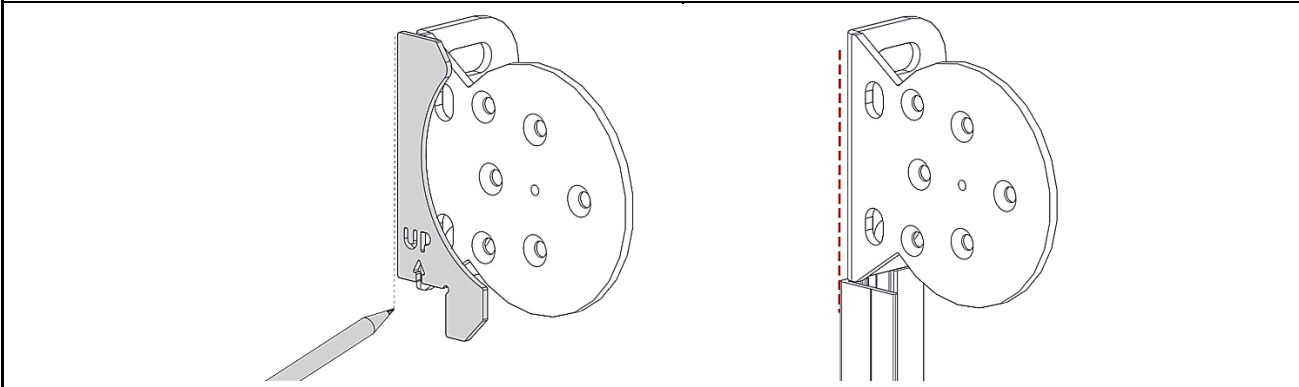

Use thickness of Open Bracket Template to mark position of L-Fastener Rail

WALL MOUNT U-MOUNTING RAIL

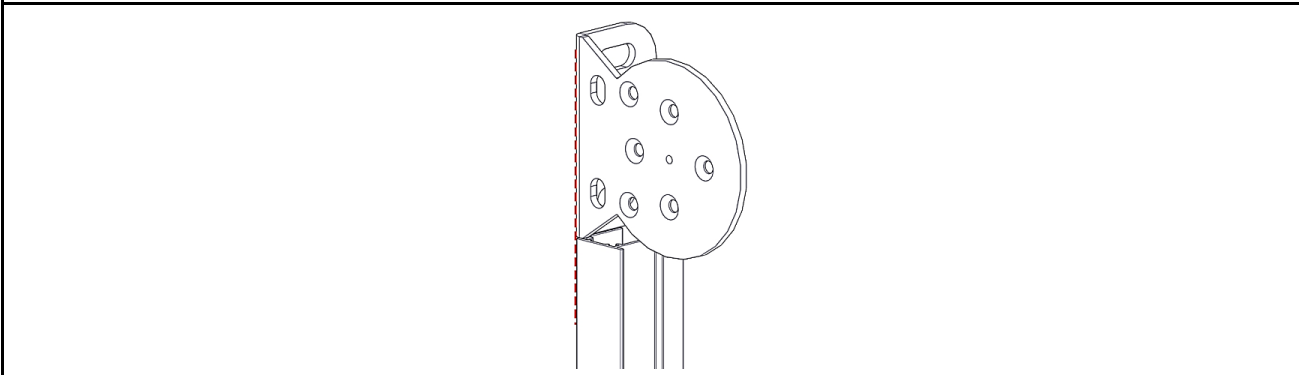

Rail to sit flush to bracket

STEP 2 – MOUNT L-FASTENER RAIL TO WALL ON BOTH SIDES (FOR WALL MOUNT ONLY)

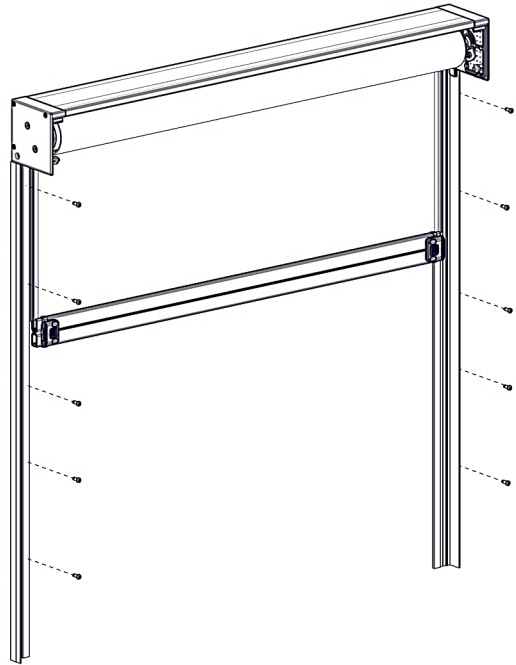
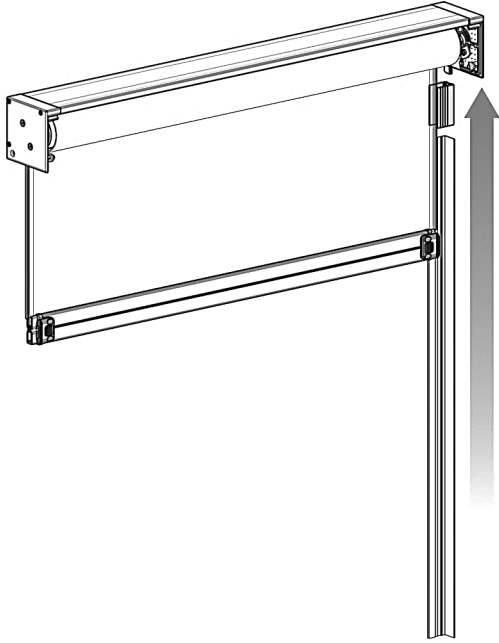

Use an off cut of the U mounting rail to install the L-fastener rail at the correct distance from the end plate.

STEP 3 – INSERT U-MOUNTING RAIL/WALL MOUNT U-MOUNTING RAIL

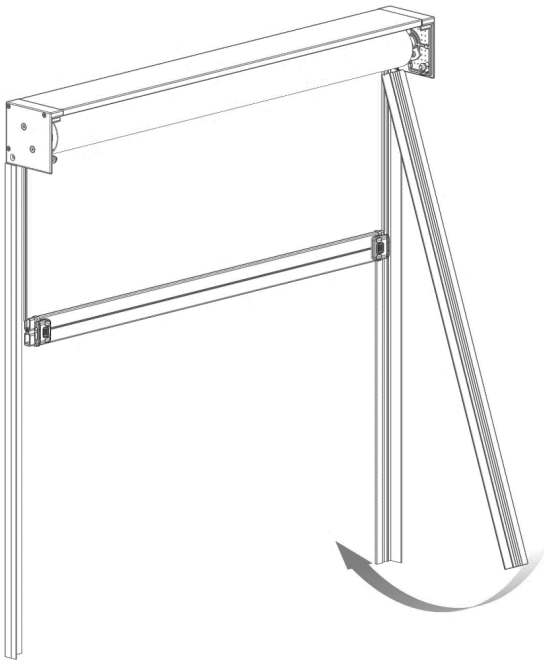

Locate ear of end plate with U-mounting rail

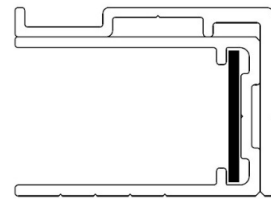

L-Fastener Rail + U-Mounting Rail + ear of end plate

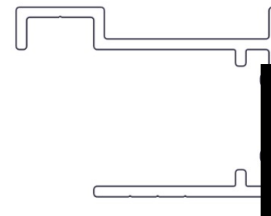

Wall mount U-Mounting Rail + ear of end plate

STEP 4 – SECURE U-MOUNTING RAIL TO INSIDE MOUNT SURFACE OR L-FASTENER RAIL

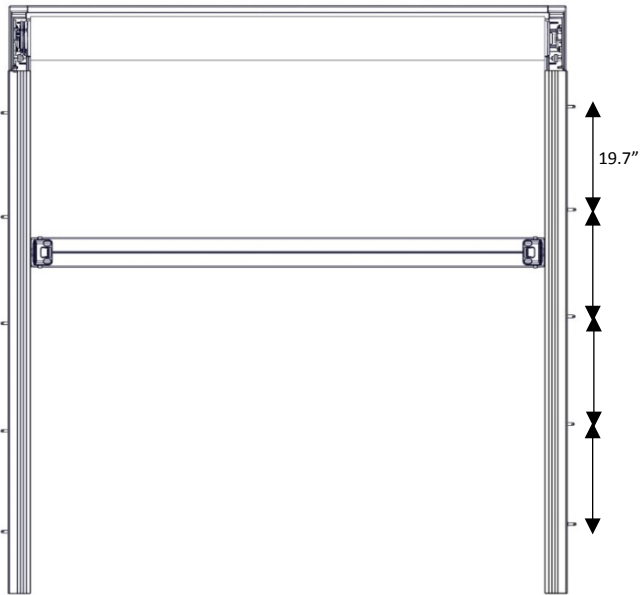

WALL MOUNT: L – Fastener Rail

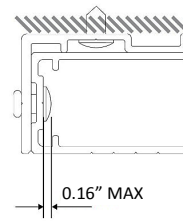

WALL MOUNT: U – Mounting Rail

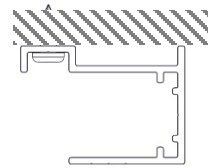

INSIDE MOUNT

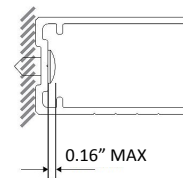

STEP 5 – REMOVE THE STOPS FROM THE FUNNEL IN THE INNER RAILS

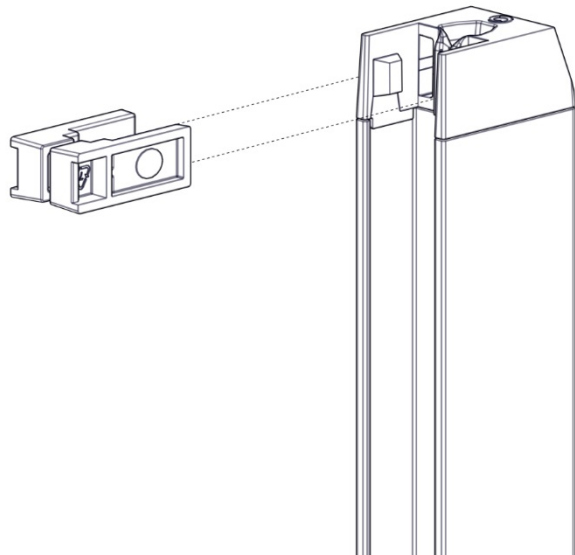
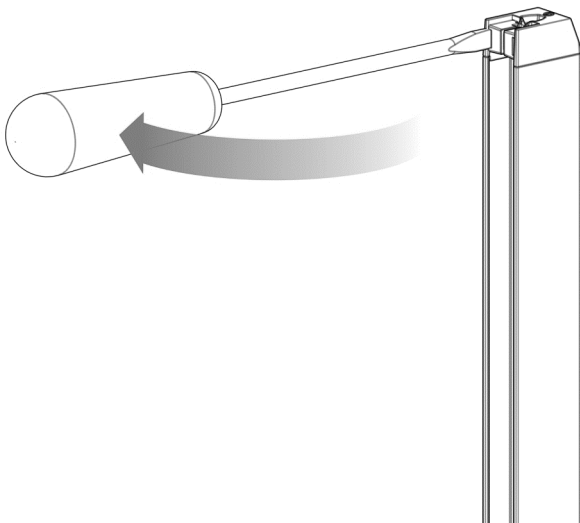

Use flat head screw driver to pry both stops out

STEP 6 – SWING INNER RAIL INTO THE U MOUNTING RAIL ON AN ANGLE ON BOTH SIDES

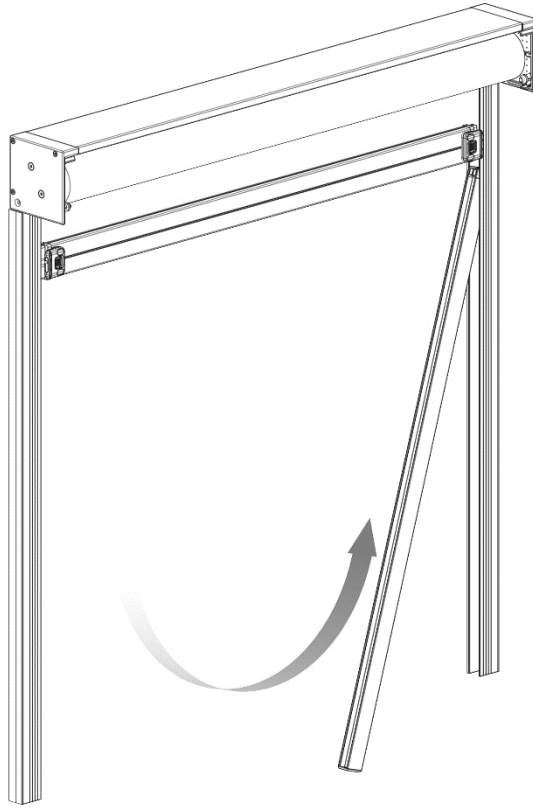

Ensure weight bar is 1.97" - 3.94" from box
Feed zip into funnel
If issues are encountered refer to Section 4 - Troubleshooting (Item 8)

STEP 7 – PUT STOPS BACK INTO FUNNEL

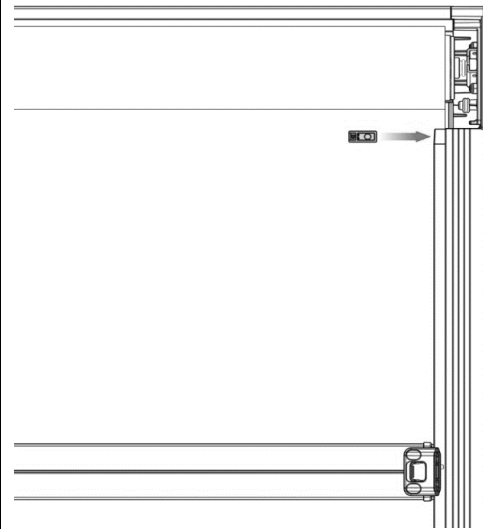
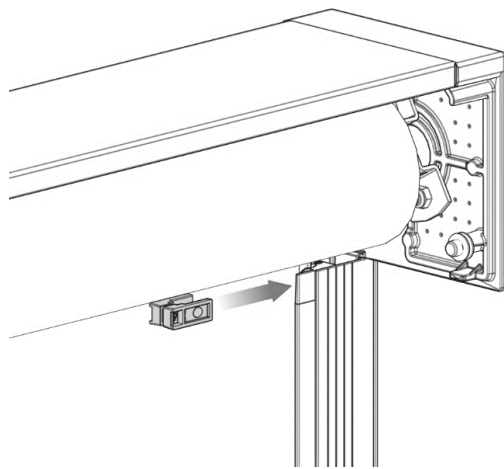

If there is inadequate access to the back of the shade to attach stops, add only one to the front of the shade on both ends

STEP 8 – OPERATE SHADE MULTIPLE TIMES TO ALLOW INNER RAIL TO MOVE INTO NATURAL POSITION

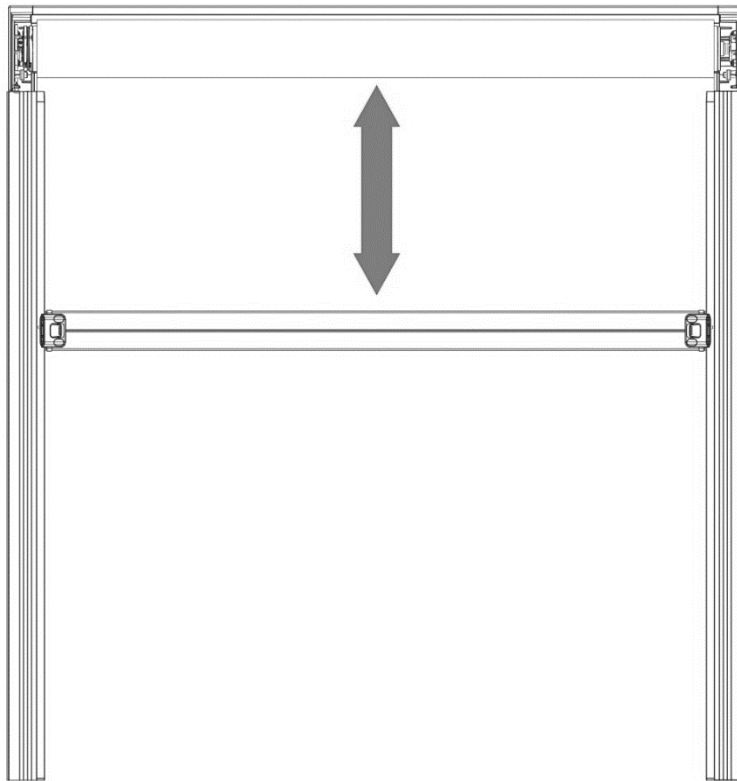

The inner rail should sit parallel with the zip to avoid strain or jamming of shade during operation
Ensure the zip is running inside the inner rail on both sides.

STEP 9 – SECURE THE INNER RAILS

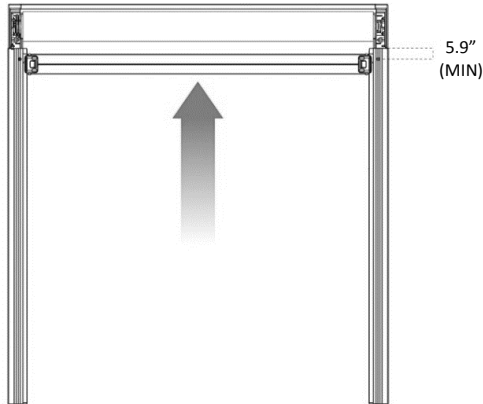

Run the shade up and secure the inner rails at the top of the shade on both sides

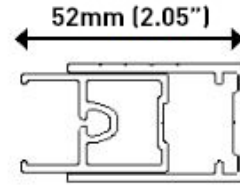

Screw/ Rivet inner rail at central position.

Pre-drill 0.16" holes for rivets.
 Rivet: Dome head, body diameter 0.16"
 Grip range: 0.19" – 0.25" stainless steel
 Tech screws can also be used to secure Inner rail into place.

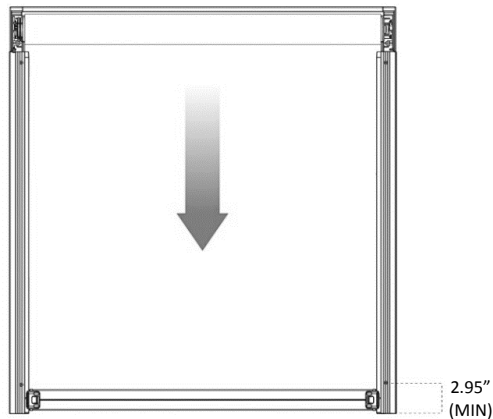

Run the shade down and secure the inner rail at the bottom on both sides
 Ensure inner rail is level before fastener

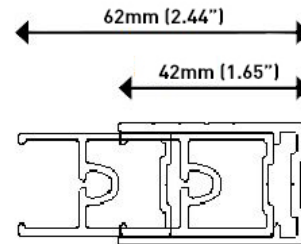

The overall dimension of the U mounting rail and Inner rail must be between 1.65" – 2.44".

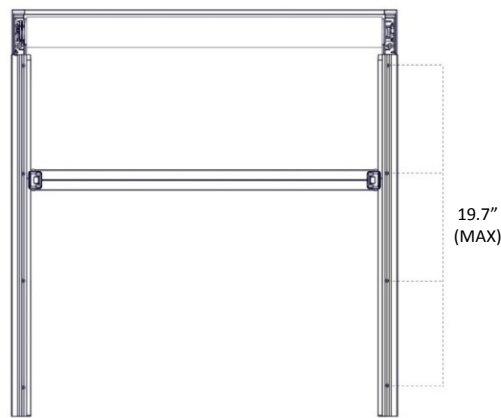

Move the shade to the next fastener position and secure the inner rails along the length of the shade on both sides.
 Do not force the inner rail; it should be in its natural position.

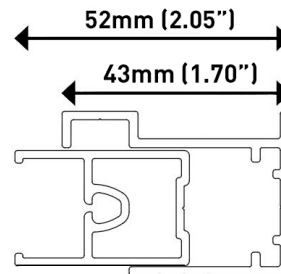

The overall dimension when using Wall mount U Mounting Rail and inner rail is 1.70" – 2.05"

STEP 10 – TEST OPERATION AND APPEARANCE OF SHADE

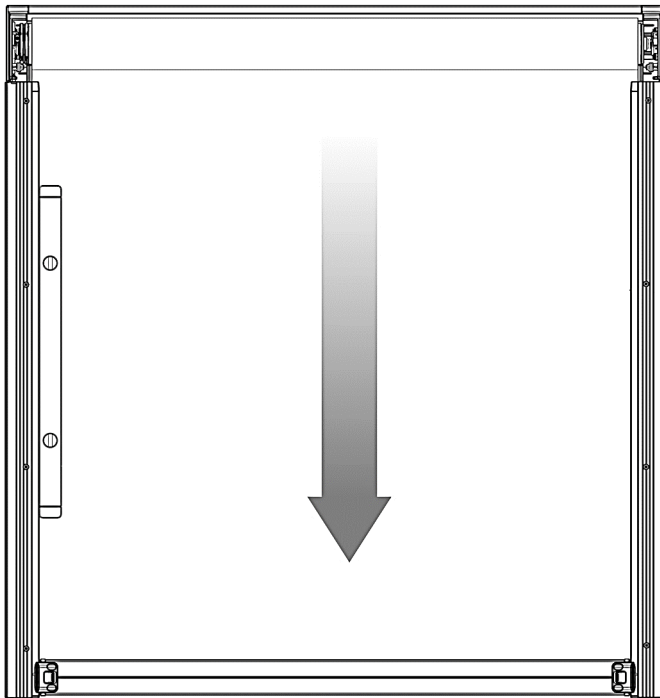

Check inner rails are level and parallel

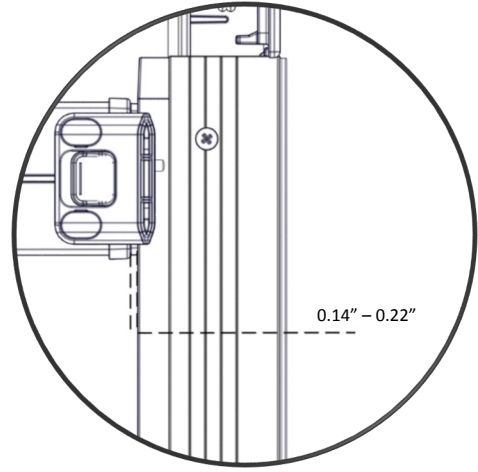

IMPORTANT:

The distance between the weight bar end cap and the edge of the inner rail should always be between 0.14" – 0.22"

STEP 11 – SET MOTOR LIMITS (MOTOR CONTROL ONLY)

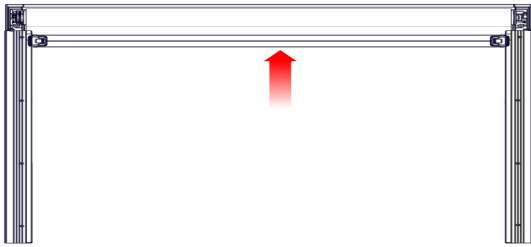

TOP LIMIT: Set top limit as required (should be as close to the box as possible)



BOTTOM LIMIT: Set to the lowest point possible. Ensure seal is compressed as much as possible.

PART H –ULTRA-LOCK LATCH INSTALLATION

STEP 1 – DEACTIVATE FABRIC TENSION MODE (IF FT MODE IS ON)

Refer to Automate FT Programing Instructions

STEP 2 – SLIDE LATCH OVER LOCK BODY ON BOTH ENDS OF WEIGHT BAR



Identification: Triangle on rotating cam will point to the hand of the product (see below)

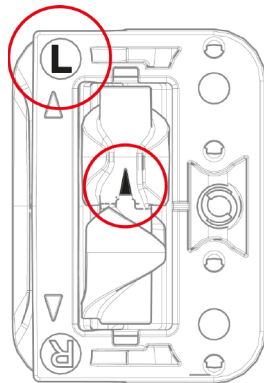

LH LATCH

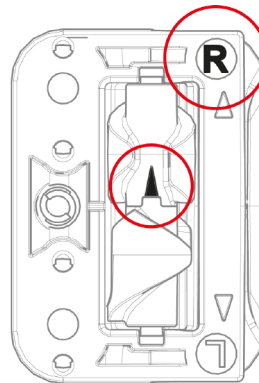

RH LATCH

STEP 3 – IDENTIFY HIGHEST POINT ON FLOOR/GROUND

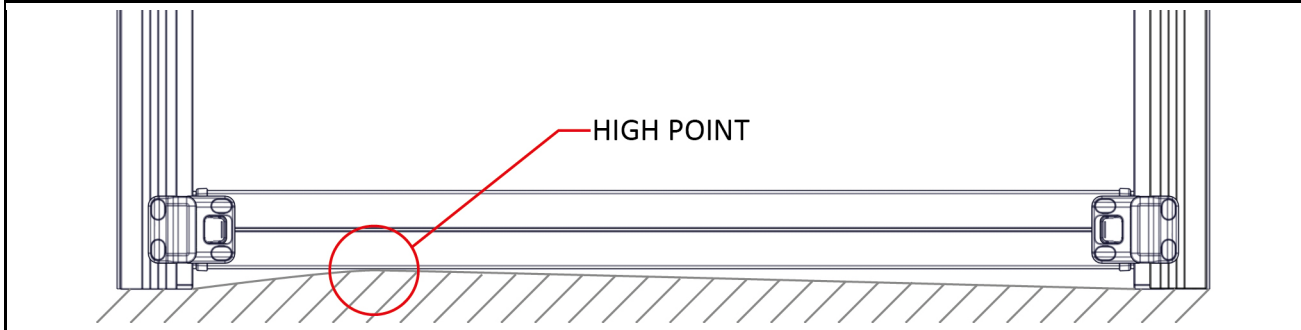

STEP 4 – IDENTIFY WEIGHT BAR POSITION FOR LOCK

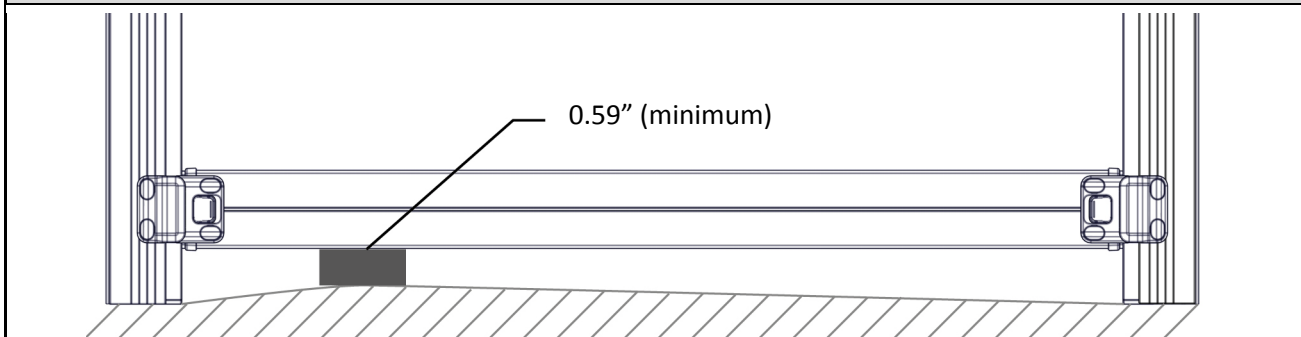

Note: It is recommended to use a 0.59" packer/spacer at the "High Point" and allow weight bar to rest at this point.

STEP 5 – ENSURE WEIGHT BAR IS LEVEL

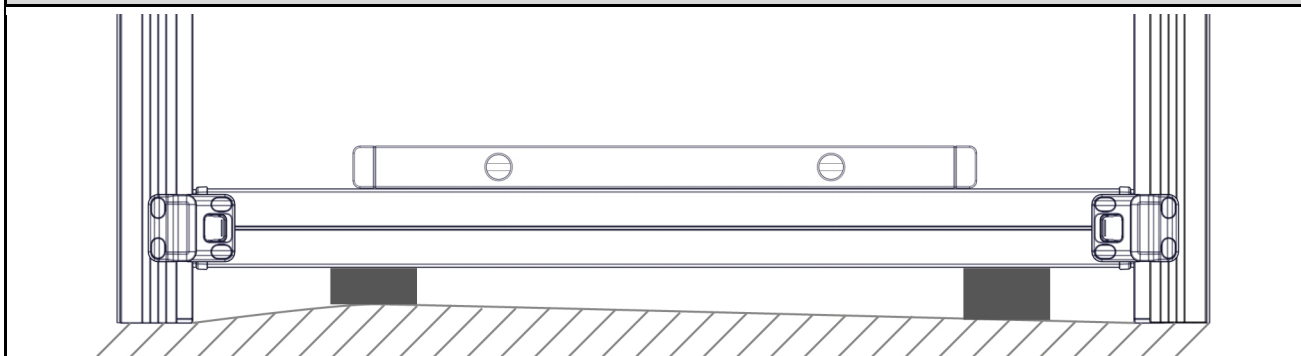

Note: It is recommended that another packer/spacer be used to keep weight bar level whilst drilling.

STEP 6 – FIX LATCHES INTO POSITION

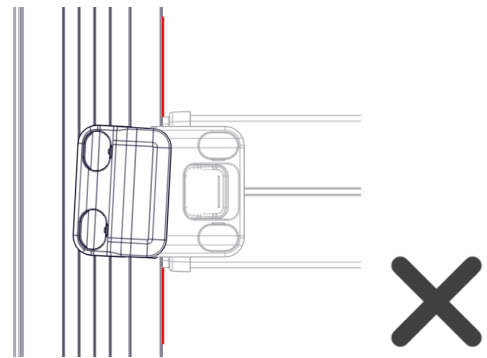
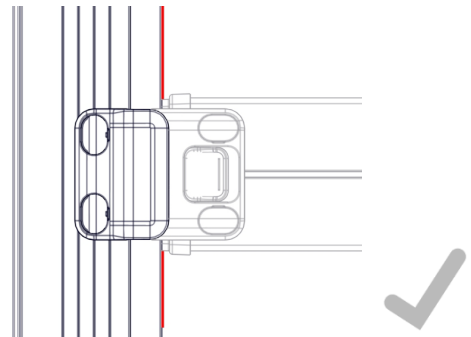
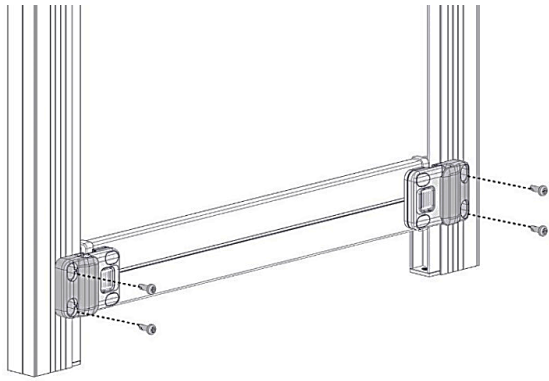

Ensure Latch is not twisted

STEP 7 – ATTACH SCREW COVERS

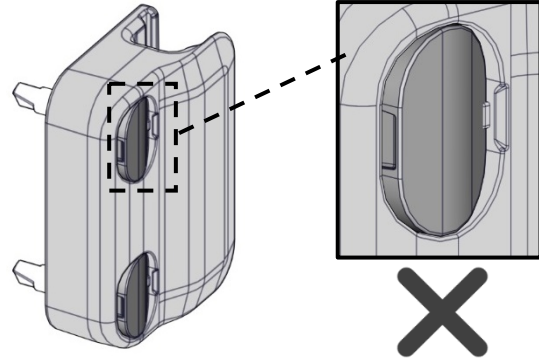
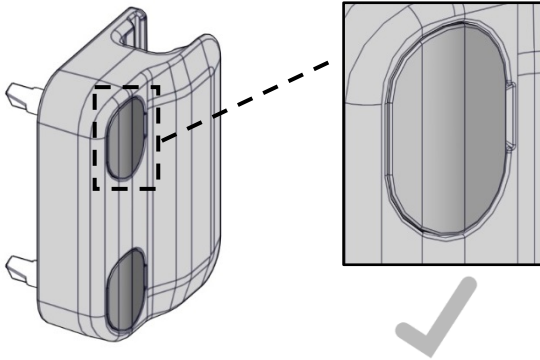
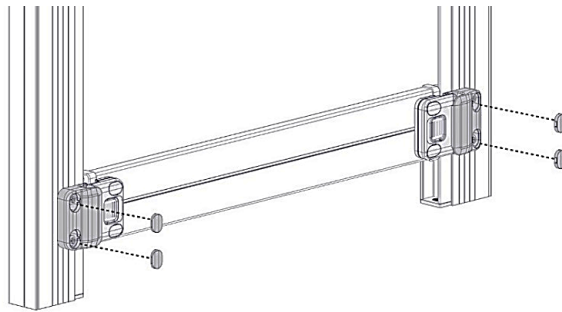

NOTE: Ensure screw covers are installed correctly and flush fitting

STEP 8 – RELEASE WEIGHT BAR FROM LOCKS

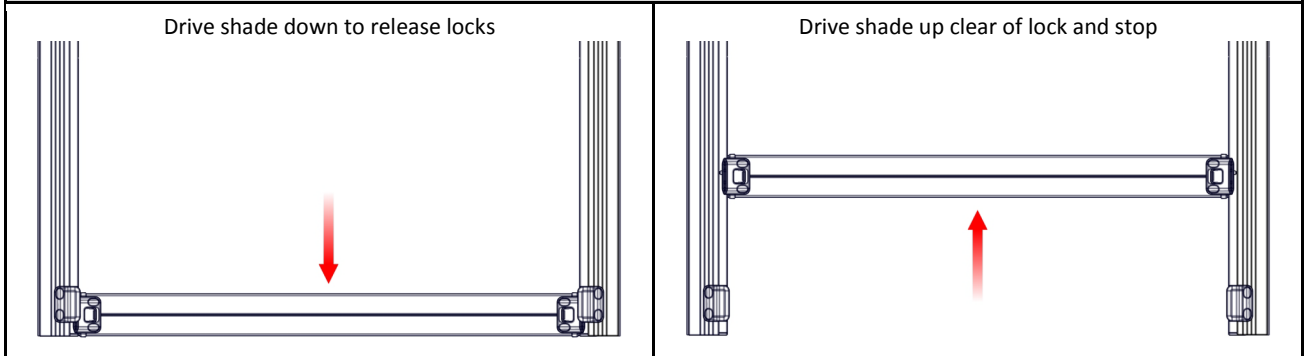

STEP 9 – ACTIVATE FABRIC TENSION MODE

Refer to Automate FT Programming Instructions

STEP 10 – OPERATE SHADE WITH LOCKS

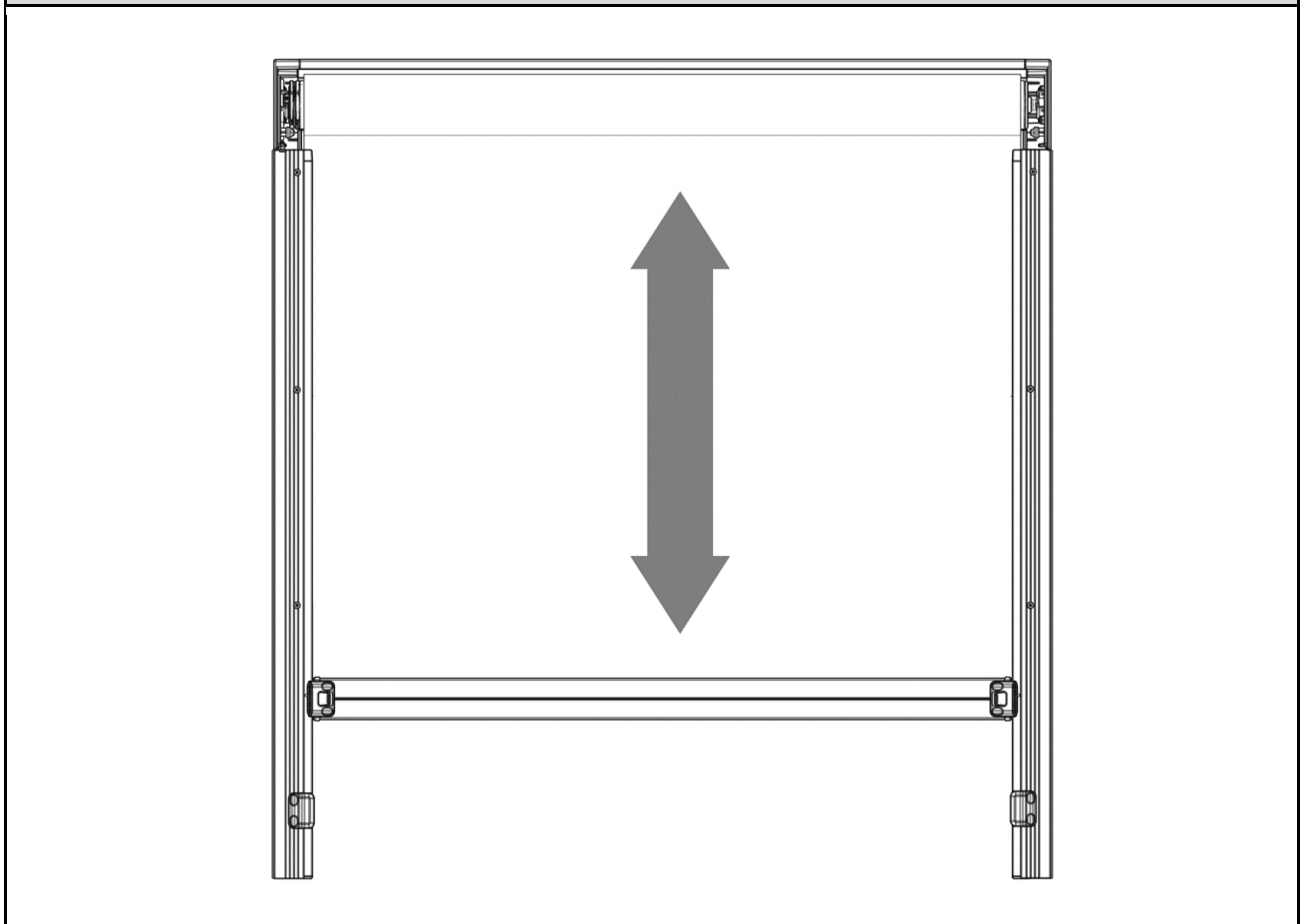

PART I – ULTRA-LOCK TROUBLE SHOOTING

DEFINITIONS

Scenario 1 – refers to the situation where one lock is engaged and the other is disengaged causing the weight bar to be on an angle



FIGURE 1

Scenario 2 – shade will not raise higher than 3.93" from ground/shade locks when pressing up on the remote

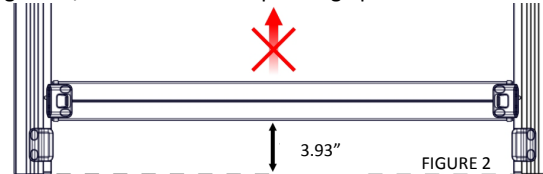

FIGURE 2

Release Latch – releasing the pin in order to release the Ultra-Lock (see below for how to release)

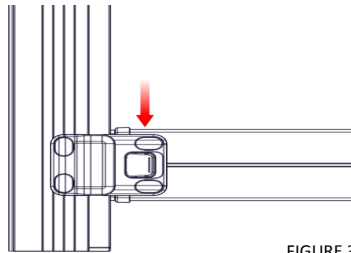

FIGURE 3

Push down on weight bar to release tension

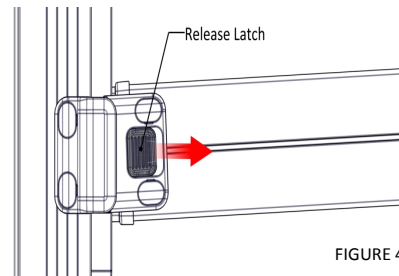

FIGURE 4

Slide release latch to unlock pin

Obstruct Weight Bar – prevent weight bar from descending into locks with an obstruction

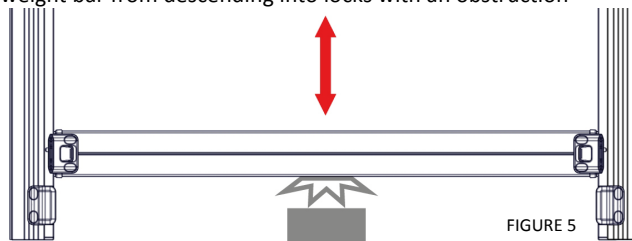

FIGURE 5

Proper Functionality – when pressing up on the remote the shade retracts all the way

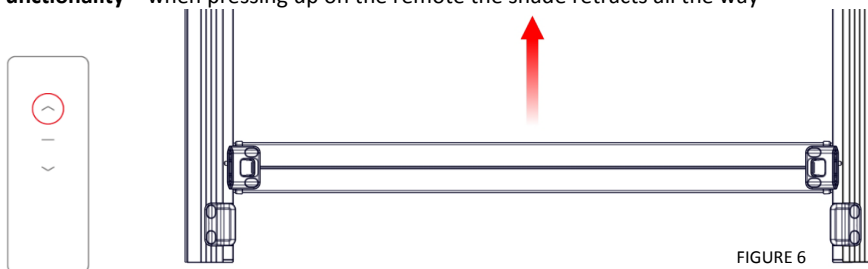

FIGURE 6

SOLUTIONS

Scenario 1 (see figure 1)

Step 1: 'Release Latch' on locked side (see figure 3 & 4)

Step 2: 'Obstruct weight bar' (figure 5) & Press **UP/DOWN** on remote until 'proper functionality' is achieved (see figure 6)

Scenario 2 (see figure 2)

Step 1: If possible, Press **DOWN** on remote to release locks, if not proceed to Step 2

Step 2: 'Obstruct weight bar' (figure 5) & Press **UP** on remote until 'proper functionality' is achieved (see figure 6)

PART J – WEIGHT BAR SB07 LATCH INSTALLATION

STEP 1 – BRING WEIGHT BAR TO DESIRED LOCKED POSITION

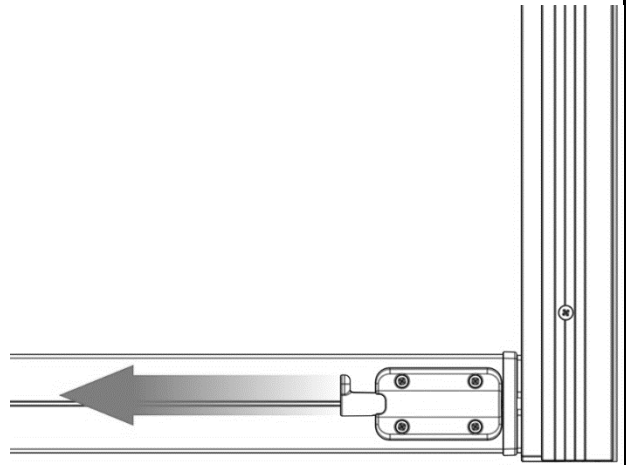
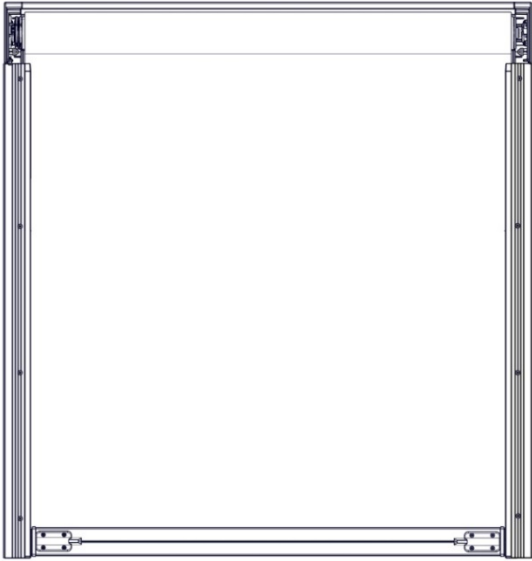

Ensure shaft of the lock is retracted

STEP 2 – SECURE LATCH TO U-MOUNTING RAIL

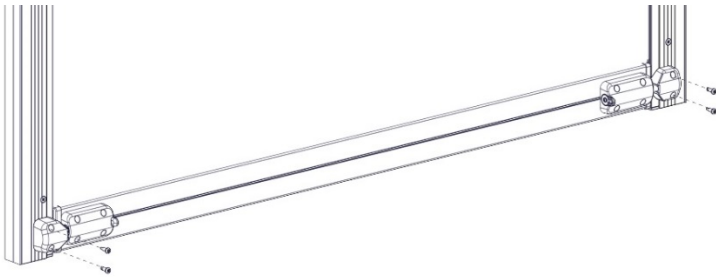

Align lip of latch to U-Mounting Rail

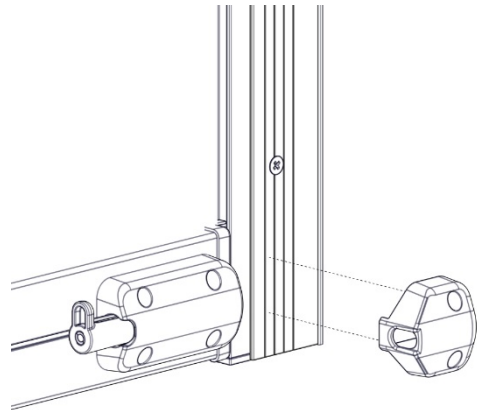

STEP 3 – ADD ADDITIONAL LATCHES (IF REQUIRED)

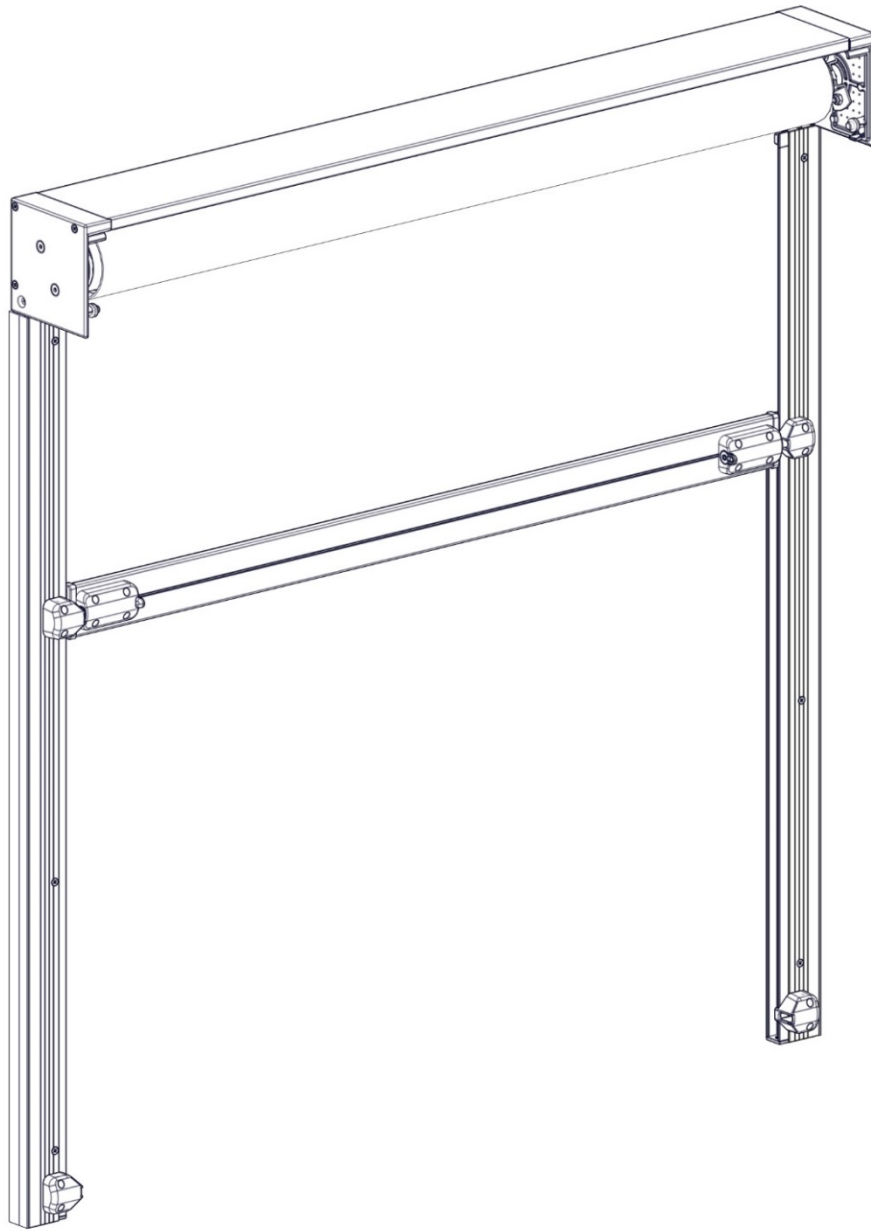

PART K – INSERT BOX / FASCIA

STEP 1 – SWING BOX COVER INTO BOX TOP AND CLIP INTO PLACE



STEP 2 – SECURE COVER AT BOTH ENDS (IF REQUIRED)

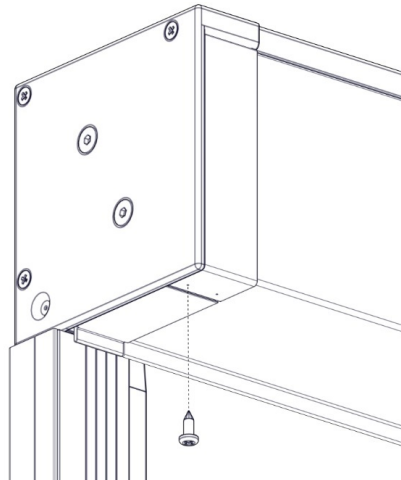

SECTION 3 – INSTALLATION SCENARIOS

PART A – MULTIPLE SHADES INSTALLED SIDE BY SIDE ON A WALL MOUNT INSTALLATION

STEP 1 – MARK OUT CORRECT POSITION WHERE COMPLETE WALL MOUNT SHADES ARE TO BE INSTALLED



It is important to install the shades so that they match the initial measure.

STEP 2 – INSTALL BOX OR BRACKETS FOR SHADE 2



BLIND 2

Refer to Section 2, Parts C

STEP 3 – INSTALL L FASTENER RAILS FOR SHADE 2



BLIND 2

Refer to Section 2, Part G

STEP 4 – ENSURE L FASTENER RAILS ARE AT THE CORRECT WIDTH FOR SHADE 2

Adjust L fastener rails if required.
If shade 02 occupies installation
space allocated to shade 1 or shade 3,
operational or installation problems
will occur with these shades.

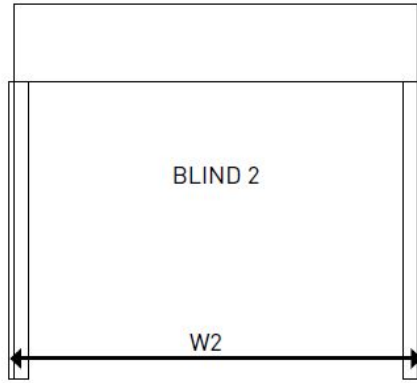

STEP 5 – INSTALL BOX OR BRACKETS FOR SHADE 1 & 3

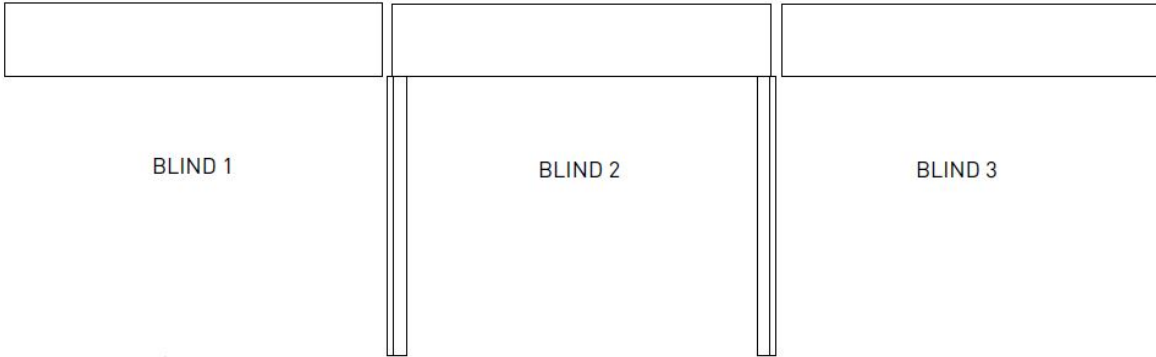

Refer to Section 2, Parts C

STEP 6 – INSTALL L FASTENER RAILS FOR SHADE 1 & 3

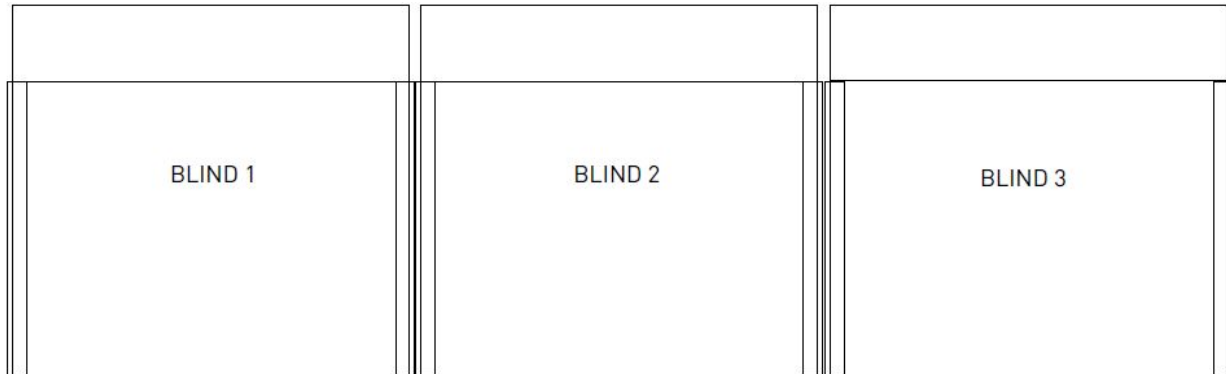

Refer to Section 2, Part G

STEP 7 – ENSURE L FASTENER RAILS ARE AT THE CORRECT WIDTH FOR SHADES 1 & 3

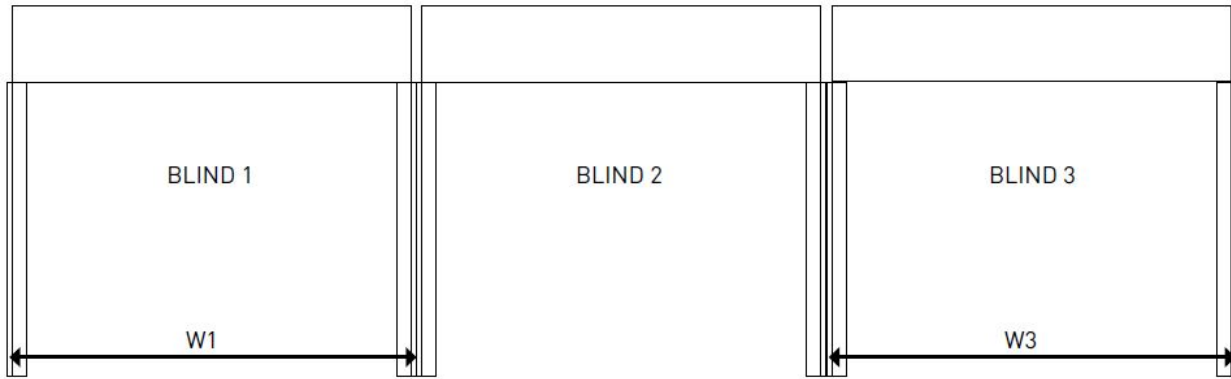

Adjust L fastener rails and box or bracket installation if required.

STEP 8 – ATTACH U MOUNTING RAILS ON SHADES 1, 2 & 3

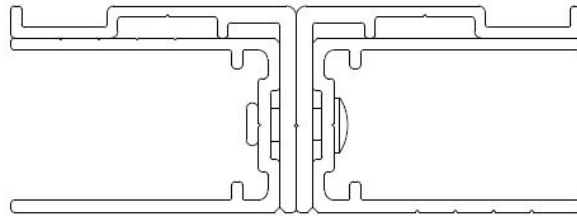

Rivet U Mounting rails to L fastener rails to all 3 shades

STEP 9 – COMPLETE SHADE INSTALLATION FOR SHADE 2

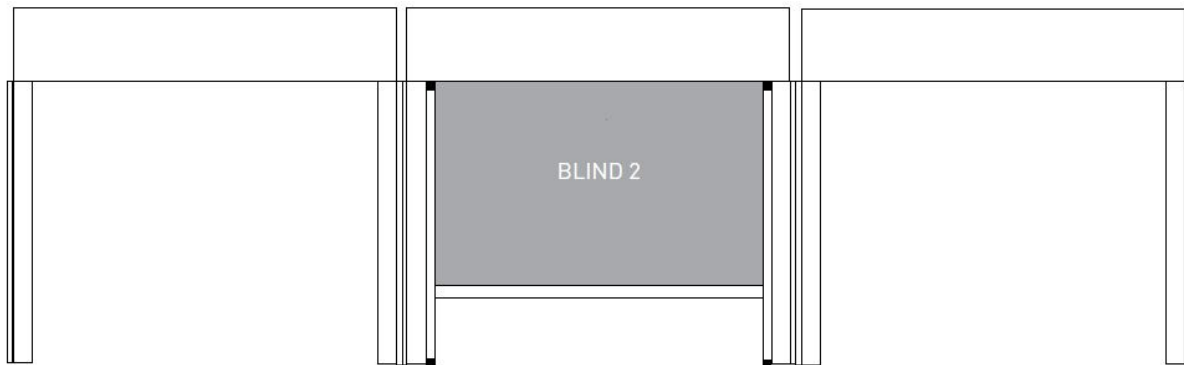

Ensure shade is correct width as specified in initial measure.

STEP 10 – COMPLETE SHADE INSTALLATION FOR SHADE 1 & 3

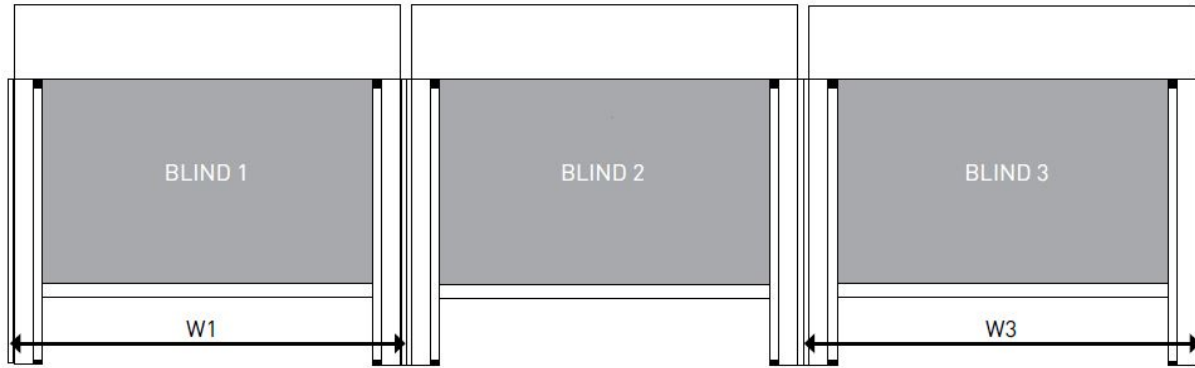

Ensure shades are correct width as specified in initial measure.

FOR MORE THAN 3 SHADES

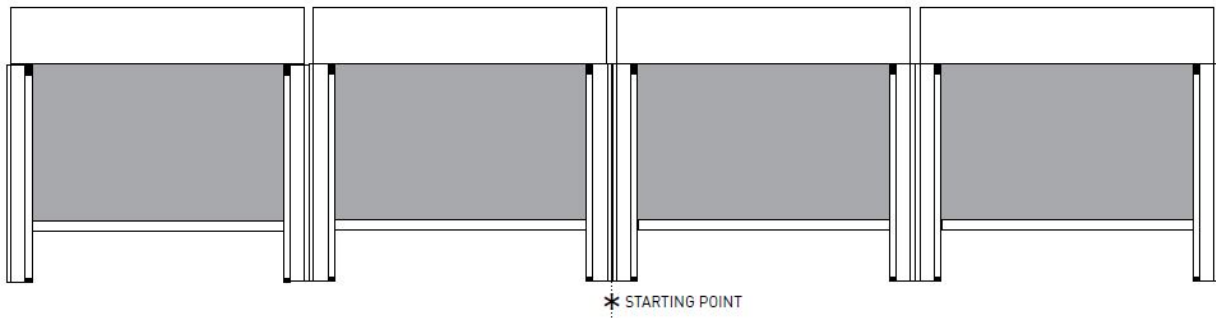

Apply same principles outlined in previous steps when there are several shades side by side

SECTION 4 – TROUBLESHOOTING

NO.	PROBLEM	CAUSE	SOLUTION
1	Prominent smile across fabric	Not enough tension in side guides	Cut new fabric skin and weld zip onto fabric ensuring temperature is not too hot. Refer Assembly manual, Section, Section E, Part 3, Step 2 for welding tips.
		Fabric is not installed straight	Ensure fabric is assembled straight onto tube and weight bar.
2	Ripples along sides of fabric	Shade rolled up for extended period of time	This occurrence is inherent to roller systems and is more prevalent in some fabrics. Leave shade down for 1-4 hours – most ripples should disappear.
		Fabric not central to system	Remove rivets around the ripple area and reposition inner rail and secure
		Too much tension in inner rails	Check fabric is centered with system (Section D, Part 3, Step 6) If the fabric is not centered with the system, center the fabric. The Side Rails may need to be removed to correct. If fabric cannot be centered, check scallop in fabric is large enough for installation (Assembly manual, Section E, Part 3, Step 5). If the fabric at the scallop is flush with the edge of the tube and the fabric cannot move sideways any further, increase size of scallop in fabric.
		Fabric is too wide for installation	Check actual installation width dimension matches the measured shade width. If the installation width does not match the measured shade width: <ul style="list-style-type: none"> • Correct installation width to match measured shade width or <ul style="list-style-type: none"> • Correct fabric width to correct size (based on actual installation width) Note: Tube and weight bar may also require correcting Refer Assembly Manual, Section D If the installation width matches the measured shade width: Check overall fabric width from external zip edge to external zip edge and ensure it is W-66mm (W being completed shade width). If required, correct fabric width.
		Not enough weight in weight bar.	Refer to product specs. Add ballast. Refer Assembly Manual, Section F, Part 8a or 8b, Step 3 Note: for spring operated shades, the number of pre-turns will most likely need to be increased.
		Spring operated shades	It is more common for there to be some ripples in spring operated shades. To reduce the number of ripples evident pull the shade down softly and lock into position.
		Not enough pre-turns in spring	Increase number of pre-turns on spring. Refer to Section C & Section D, Part 3, Steps 7-10

		Installation is not square	Check overall width of U-mounting rail and inner rail is within 1.65" – 2.44" (Section D, Part 4, Step 9). Check inner rails are level & parallel (Section D, Part 4, Step 10). If either of the above checks are not in accordance with specifications, the installation space requires additional packing. The side rails or entire systems may need to be removed to correct. Refer Section B
		Fabric permanently damaged due to inadequate handling during assembly, transportation, installation or use	Replace the fabric and ensure it is handled with care.
		Fabric is not installed straight	Ensure fabric is assembled straight onto tube and weight bar.
3	Small ripples close to weld	Welding temperature is too high on zip	Cut new fabric skin and weld zip onto fabric ensuring temperature is not too hot. Refer Assembly manual, Section, Section E, Part 3, Step 2 for welding tips.
4	Shade gets jammed half way down	Weight bar end cap hits Inner Rail	Check there is always 0.14"- 0.22" gap between Weight Bar End Cap and Inner Rail (Section D, Part 4, Steps 9 & 10). If there is insufficient clearance, check: <ul style="list-style-type: none"> • Actual installation width dimension matches the measured shade width • The weight bar length is cut in accordance with the deductions outlined by Acmeda If the installation width does not match the measured shade width: <ul style="list-style-type: none"> • Correct installation width to match measured shade width or • Trim weight bar length to correct size (based on actual installation width) Note: Tube and fabric may also require correcting Refer Assembly Manual, Section D
		Fabric is not installed straight	Ensure fabric is assembled straight onto tube and weight bar.
5	Spring operated shade is heavy to push up	Not enough pre-turns	Increase number of pre-turns on spring. Refer to Section C & Section D, Part 3, Steps 7-10
6	Spring operated shade is stuck and will not move	Spring pre-tension Idler has not been un-locked.	Ensure pre-tension Idler is unlocked on both ends of system. Refer Section D, Part 3, Step 3.
7	Motorized shade jolts during operation	Motor rotates shade continuously whilst a wind gust causes additional friction in	This occurrence is inherent to the motorized system and no damage will be caused as a result. If undesired, avoid operating shade in windy conditions.

		Inner Rail and stops shade momentarily. When force of wind is reduced, the additional friction is removed and shade drops.	
		Not enough weight in weight bar	Add ballast to weight bar. Refer Assembly Manual, Section F, Part 8a or 8b, Step 3
8	Cannot install inner rail into shade to feed zip	Weight bar length is too long	Check actual installation width dimension matches the measured shade width. If the installation width does not match the measured shade width: • Correct installation width to match measured shade width or • Trim weight bar length to correct size (based on actual installation width) Note: Tube and fabric may also require correcting Refer Assembly Manual, Section D
		Inner rail length is too long	Check actual installation drop dimension matches the measured shade drop. If the installation drop does not match the measured shade drop: • Correct installation drop to match measured shade drop or • Trim inner rail length to correct size (based on actual installation width) Note: U-mounting rail and L-fastener channel may also require correcting Refer Assembly Manual, Section D
		Weight bar stops still in funnel	Remove stops from funnel. Refer Section D, Part 4, Step 5
9	SB07 Weight bar lock doesn't locate into latch	Latch has not been secured in correct position	Re-install latch so shaft locates into latch. Refer Section D, Part 5, Steps 1 & 2
10	Uneven weight bar	Box is not level, thus weight bar appears uneven	Ensure box is level. Refer Section D, Part 1, Step 2
		Inconsistent friction along inner rails	Check inner rails are level & parallel (Section D, Part 4, Steps 9 & 10). If the inner rails are not level and parallel remove rivets from U-mounting channel, reposition inner rail to reduce tension and re-secure inner rail. Refer Section D, Part 4, Steps 8-10
		Motorized shade jolts during operation	See Point 7
		Zip overturns on itself	This occurrence is inherent to Zipscreen and there isn't currently a solution.

		Fabric is not installed straight	Ensure fabric is assembled straight onto tube and weight bar.
12	Ultra-Lock is out of sync	Locks are not level	Release Ultra Lock using Release Latch and reset locks.
		Uneven Weight Bar (see item 10 above)	
		Obstruction preventing weight bar lowering through lock	Remove obstruction to allow weight bar to reach its lowest point.
13	Collision Control function of Automate FT motor is not active.	The Automate FT motor collision control function isn't active in the first 7.9" from the upper limit and in the last 7.9" from the lower limit.	Put the shade up or down, increasing the distance from the limits and verify if the motor retracts the shade when an obstacle is detected.
		Collision control function has been deactivated during motor installation.	Press P2, Stop & Down on the remote and check the functionality of collision control again.